

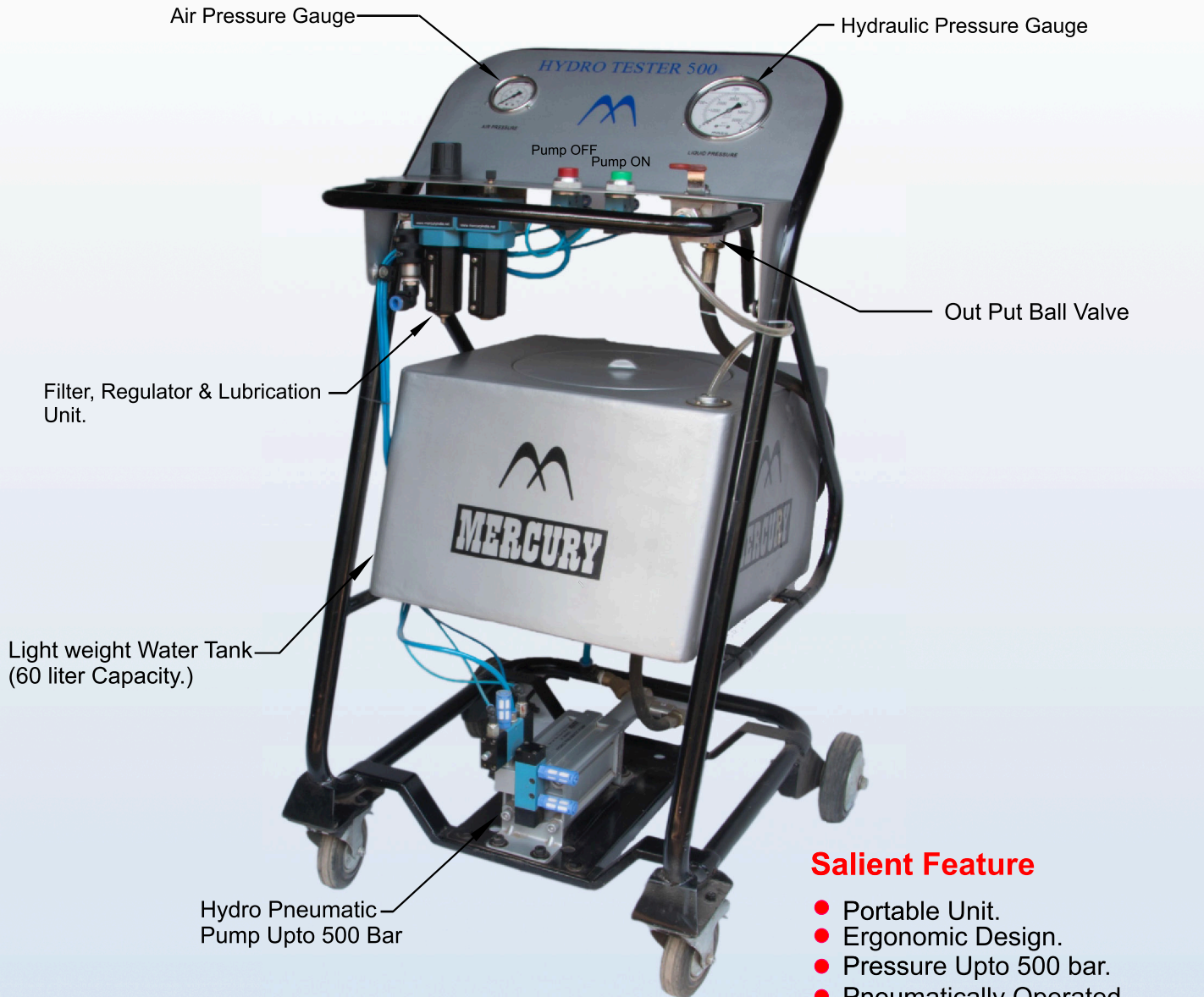

HYDRO TESTER 500
(SERIES PORTABLE TEST UNIT)



Salient Feature

- Portable Unit.
- Ergonomic Design.
- Pressure Upto 500 bar.
- Pneumatically Operated.
- Entire pressure testing Circuit Inbuilt.
- Light weight & Easy to handle.
- Robust construction.



“Mercury” Hydro tester is a portable testing unit for pressure ranging from 15 bar to 600 bar. This indigenous product has the entire pressure testing circuit inbuilt to simplify the testing process and increase flexibility in testing heavy products at its place of manufacturing. Light weight components, ergonomic design & good esthetics are some of the distinguishing features of the Hydro tester series.

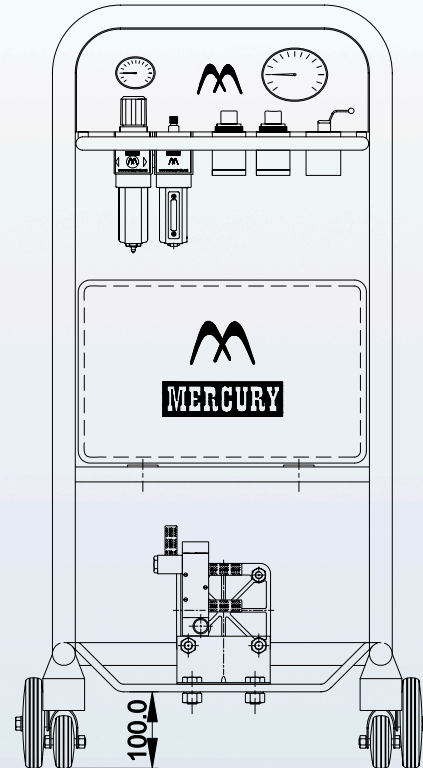
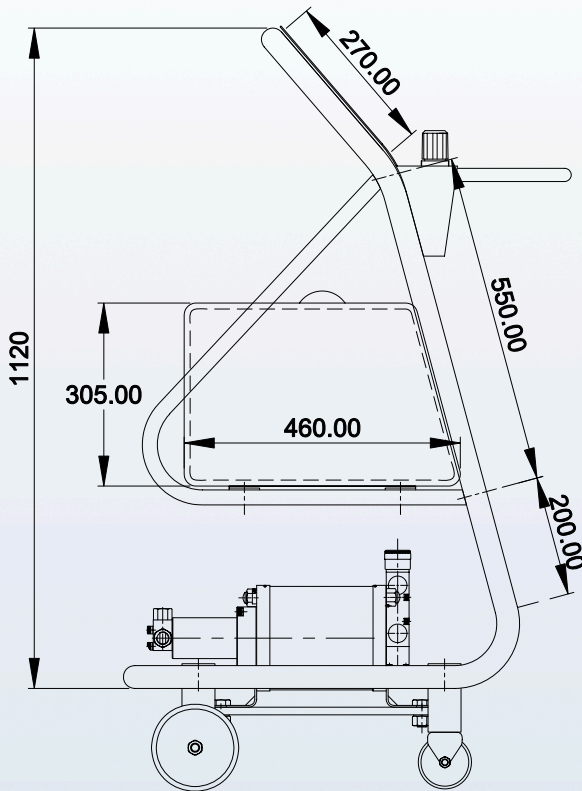

| PRESSURE RANGE 0-255 BAR | | | |
|--------------------------|-------|--|-----------|
| MODEL No. | RATIO | OUTPUT PRESSURE AT 5Kg/cm ² | NRV MODEL |
| PTU - LP - A80-14 | 32 | 160 | LP3 |
| PTU - LP - A80-16 | 25 | 125 | LP3 |
| PTU - LP - A80-20 | 16 | 80 | LP3 |
| PTU - LP - A80-28 | 8 | 40 | LP3 |
| PTU - LP - A80-32 | 6.25 | 31 | LP3 |
| PTU - LP - A100-14 | 51 | 255 | LP3 |
| PTU - LP - A100-16 | 39 | 195 | LP3 |
| PTU - LP - A100-20 | 25 | 125 | LP3 |
| PTU - LP - A100-28 | 12.75 | 64 | LP3 |
| PTU - LP - A100-32 | 9.75 | 49 | LP3 |
| PTU - LP - A160-28 | 32 | 160 | LP3 |
| PTU - LP - A160-32 | 25 | 125 | LP3 |

| PRESSURE RANGE 15-80 BAR | | | |
|--------------------------|-------|--|-----------|
| MODEL No. | RATIO | OUTPUT PRESSURE AT 5Kg/cm ² | NRV MODEL |
| PTU - HF - A100-40 | 6.25 | 31 | HF 2 |
| PTU - HF - A100-56 | 3 | 15 | HF 2 |
| PTU - HF - A160-40 | 16 | 80 | HF 2 |
| PTU - HF - A160-56 | 8 | 40 | HF 2 |
| PTU - HF - A160-80 | 10 | 50 | HF 2 |

| PRESSURE RANGE 300-500 BAR | | | |
|----------------------------|-------|--|-----------|
| MODEL No. | RATIO | OUTPUT PRESSURE AT 5Kg/cm ² | NRV MODEL |
| PTU - HP - A80-10 | 64 | 320 | HP 2 |
| PTU - HP - A100-10 | 100 | 500 | HP 2 |
| PTU - HP - A160-16 | 100 | 500 | HP 2 |
| PTU - HP - A160-20 | 64 | 320 | HP 2 |