



3/2 Hand Slide Valves



Mechanical Characteristic

Body	: Aluminium
Orifice	: Refer to technical data
Ports	: BSP Female + 1No. Male x Male Nipple
Seals	: Nitrile Rubber
Weight	: Refer to technical data

Operating Conditions

Media	: Compressed Air
Temperature Range	: +5° to +50°C
Pressure Range	: 0 to 10 bar
Leakage	: Bubble Tight
Flow (NLPM) at 5 bar	: Refer to technical data



1/4", 3/8", 1/2" & 3/4" BSP 3/2 Hand Slide Valves

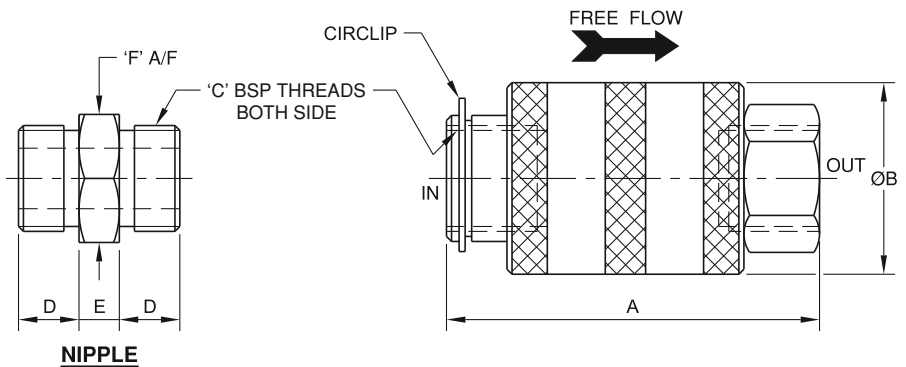

MACHINE MOUNTING

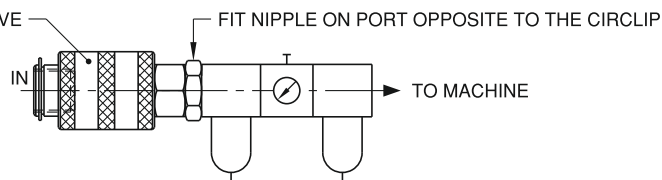

PIPE LINE MOUNTING

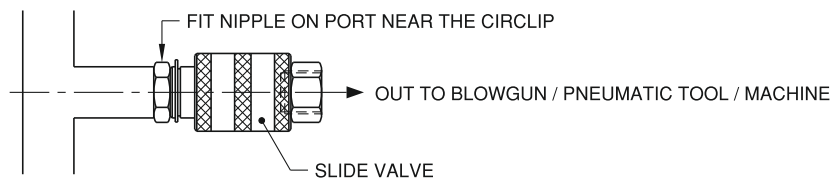

OFF

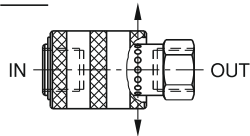

ON

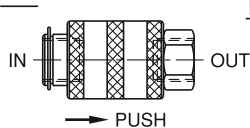

FLOW DIAGRAM

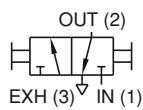

MODEL No.	SIZE BSP	ORIFICE (mm)	A	ØB	C BSP	D	E	F A/F	FLOW (NLPM)	WEIGHT (Kg.)	SEAL KIT No.
SV2	1/4"	Ø6.50	65.00	31.50	1/4"	9.00	6.00	22.20	1200	0.09	SKSV2
SV3	3/8"	Ø12.00	74.00	31.75	3/8"	12.00	8.00	22.20	2500	0.12	SKSV3
SV4	1/2"	Ø12.50	74.00	38.00	1/2"	12.00	8.00	25.40	3000	0.13	SKSV4
SV5	3/4"	Ø19.00	109.50	48.00	3/4"	14.00	10.00	31.75	8000	0.28	SKSV5