



Compact Cylinders



Salient Features

- Compact & light weight
- Single and Double acting models
- International standard 'T' slot for magnetic sensing switch
- Long life, positive locking reed switch
- Well guided piston & piston rod
- Self adjusting, low friction 'T' ring piston seal
- Rubber cushioning at both ends
- Magnetic piston with special rubber magnet as standard
- Mounting & overall dimensions to suit leading international brands
- Special mounting dimensions available on request

Mercury Pneumatics Pvt. Ltd.

C-105, Ansa Industrial Estate, Saki Vihar Rd, Andheri (E),
Mumbai - 400072. India. Phone: +91-22-40151020

E-mail: contactus@mercuryindia.net Website: www.mercuryindia.net

Compact Cylinders : Series 'S'

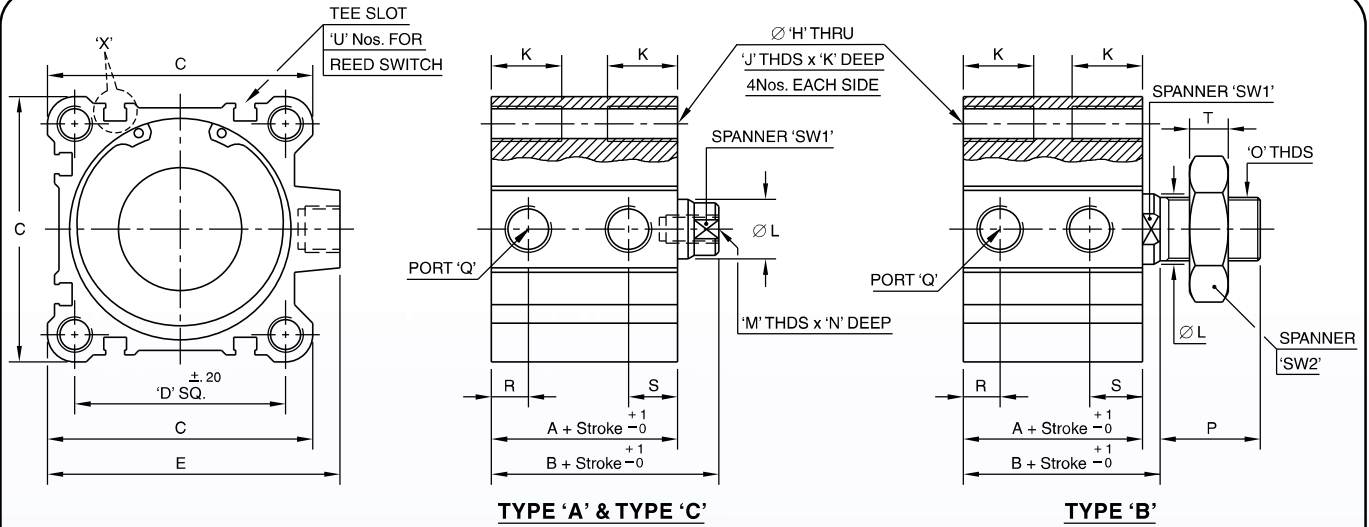

TYPE 'A' – DOUBLE ACTING, FEMALE THREADS, MAGNETIC PISTON
 TYPE 'B' – DOUBLE ACTING, MALE THREADS, MAGNETIC PISTON
 TYPE 'C' – SINGLE ACTING, FEMALE THREADS, SPRING RETURN, NON MAGNETIC PISTON

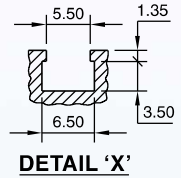

BORE DIA	MODEL No.	A	B	C	D SQ	E	Ø H	J THDS	K	Ø L	M THDS	N	O THDS	P	Q THDS	R	S	T	U	SW1	SW2	FORCE @ 5 bar (kgf)	
																						EXTEND	RETRACT
25	S25A-*	38.5	43.5	39	28	39	5.0	M6	17	10	M6	12	-	-	M5	8	10	-	3	8	-	22	18
	S25B-*	38.5	43.5	39	28	39	5.0	M6	17	10	-	-	M10x1.25	22	M5	8	10	5	3	8	17	22	18
	S25C-5	43.5	48.5	39	28	39	5.0	M6	17	10	M6	12	-	-	M5	8	10	-	3	8	-	22	2.0
	S25C-10	48.5	53.5	39	28	39	5.0	M6	17	10	M6	12	-	-	M5	8	10	-	3	8	-	22	1.4
32	S32A-*	35.5	42.5	45	34	49.5	5.0	M6	17	12	M8	16	-	-	G1/8	7.5	11	-	6	10	-	37	31
	S32B-*	35.5	42.5	45	34	49.5	5.0	M6	17	12	-	-	M10x1.25	22	G1/8	7.5	11	5	6	10	17	37	31
	S32C-5	40.5	47.5	45	34	49.5	5.0	M6	17	12	M8	16	-	-	G1/8	7.5	11	-	6	10	-	37	2.0
	S32C-10	45.5	52.5	45	34	49.5	5.0	M6	17	12	M8	16	-	-	G1/8	7.5	11	-	6	10	-	37	1.5
40	S40A-*	39.5	46.5	51	40	56.5	5.0	M6	17	16	M8	13	-	-	G1/8	8	11	-	6	14	-	60	48
	S40B-*	39.5	50.5	51	40	56.5	5.0	M6	17	16	-	-	M12x1.25	24	G1/8	8	11	6	6	14	19	60	48
	S40C-5	44.5	56.5	51	40	56.5	5.0	M6	17	16	M8	13	-	-	G1/8	8	11	-	6	14	-	60	2.3
	S40C-10	49.5	61.5	51	40	56.5	5.0	M6	17	16	M8	13	-	-	G1/8	8	11	-	6	14	-	60	2.0
50	S50A-*	40.5	48.0	62.5	50	70.5	6.8	M8	20	16	M10	15	-	-	G1/4	11.5	12.5	-	6	14	-	95	84
	S50B-*	40.5	48.0	62.5	50	70.5	6.8	M8	20	16	-	-	M16x1.5	32	G1/4	11.5	12.5	8	6	14	24	95	84
	S50C-5	45.5	53.0	62.5	50	70.5	6.8	M8	20	16	M10	15	-	-	G1/4	11.5	12.5	-	6	14	-	95	3.2
	S50C-10	50.5	58.0	62.5	50	70.5	6.8	M8	20	16	M10	15	-	-	G1/4	11.5	12.5	-	6	14	-	95	2.8
63	S63A-*	46	54	75.5	60	83.5	8.5	M10	22	20	M10	15	-	-	G1/4	11.5	12.5	-	6	17	-	150	135
	S63B-*	46	54	75.5	60	83.5	8.5	M10	22	20	-	-	M16x1.5	32	G1/4	11.5	12.5	8	6	17	24	150	135
	S63C-5	51	59	75.5	60	83.5	8.5	M10	22	20	M10	15	-	-	G1/4	11.5	12.5	-	6	17	-	150	6.7
	S63C-10	56	64	75.5	60	83.5	8.5	M10	22	20	M10	15	-	-	G1/4	11.5	12.5	-	6	17	-	150	6.0
80	S80A-*	53.5	63.5	96.5	77	103	10.2	M12	25	25	M16	21	-	-	G3/8	11.5	16	-	6	22	-	245	220
	S80B-*	53.5	63.5	96.5	77	103	10.2	M12	25	25	-	-	M20x1.5	40	G3/8	11.5	16	10	6	22	30	245	220
	S80C-5	58.5	68.5	96.5	77	103	10.2	M12	25	25	M16	21	-	-	G3/8	11.5	16	-	6	22	-	245	10.5
	S80C-10	63.5	73.5	96.5	77	103	10.2	M12	25	25	M16	21	-	-	G3/8	11.5	16	-	6	22	-	245	9.5
100	S100A-*	63	75	113	94	122	10.2	M12	25	25	M16	21	-	-	G3/8	15	21	-	6	22	-	385	360
	S100B-*	63	75	113	94	122	10.2	M12	25	25	-	-	M20x1.5	40	G3/8	15	21	10	6	22	30	385	360
	S100C-5	68	80	113	94	122	10.2	M12	25	25	M16	21	-	-	G3/8	15	21	-	6	22	-	385	11.0
	S100C-10	73	85	113	94	122	10.2	M12	25	25	M16	21	-	-	G3/8	15	21	-	6	22	-	385	10.0

* SPECIFY STROKE LENGTH WHILE ORDERING

Mechanical Characteristic	
Barrel	: Ø25, Ø32, Ø40, Ø50, Ø63, Ø80 & Ø100 - Aluminium alloy IS 63400 (6063T6)
Piston Rod	: Carbon steel IS 5517 - C35
End Caps	: Aluminium alloy IS 63400 (6063T6)
Seals	: Nitrile rubber, polyurethane (Viton for high temp. on request)

Operating Conditions	
Media	: Air (filtered 40µ & lubricated)
Temperature Range	: +5° to +50°C
Pressure Range	: 0.5 to 10 bar
Leakage	: Bubble Tight

Standard Stroke Lengths	
Ø25 - 5, 10, 15, 20, 25, 30, 40, 50	
Ø32 to Ø40 - 5, 10, 15, 20, 25, 30, 40, 50, 60, 80	
Ø50 to Ø100 - 10, 15, 20, 25, 30, 40, 50, 60, 80	

Compact Cylinders : Series 'F'

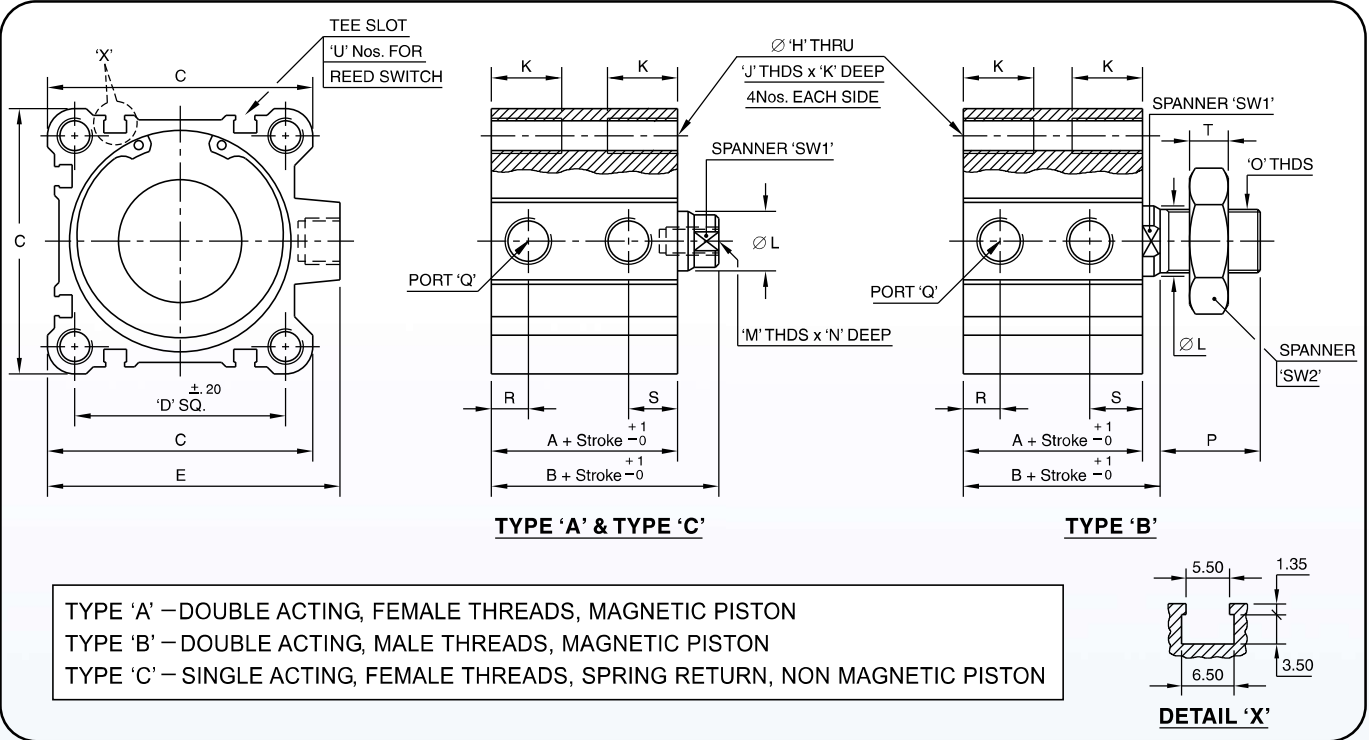

BORE DIA	MODEL No.	A	B	C	D SQ	E	Ø H	J THDS	K	Ø L	M THDS	N	O THDS	P	Q THDS	R	S	T	U	SW1	SW2	FORCE @ 5 bar (kgf)	
																						EXTEND	RETRACT
25	F25A-*	38.5	43.5	39	26	39	4.2	M5	17	10	M5	12	-	-	M5	8	10	-	3	8	-	22	18
	F25B-*	38.5	43.5	39	26	39	4.2	M5	17	10	-	-	M10x1.25	22	M5	8	10	5	3	8	17	22	18
	F25C-5	43.5	48.5	39	26	39	4.2	M5	17	10	M5	12	-	-	M5	8	10	-	3	8	-	22	2.0
	F25C-10	48.5	53.5	39	26	39	4.2	M5	17	10	M5	12	-	-	M5	8	10	-	3	8	-	22	1.4
32	F32A-*	35.5	42.5	45	32	49.5	5.0	M6	17	12	M6	12	-	-	G1/8	7.5	11	-	6	10	-	37	31
	F32B-*	35.5	42.5	45	32	49.5	5.0	M6	17	12	-	-	M10x1.25	22	G1/8	7.5	11	5	6	10	17	37	31
	F32C-5	40.5	47.5	45	32	49.5	5.0	M6	17	12	M6	12	-	-	G1/8	7.5	11	-	6	10	-	37	2.0
	F32C-10	45.5	52.5	45	32	49.5	5.0	M6	17	12	M6	12	-	-	G1/8	7.5	11	-	6	10	-	37	1.5
40	F40A-*	39.5	46.5	51	42	56.5	5.0	M6	17	16	M6	12	-	-	G1/8	8	11	-	6	14	-	60	48
	F40B-*	39.5	50.5	51	42	56.5	5.0	M6	17	16	-	-	M10x1.25	22	G1/8	8	11	5	6	14	17	60	48
	F40C-5	44.5	56.5	51	42	56.5	5.0	M6	17	16	M6	12	-	-	G1/8	8	11	-	6	14	-	60	2.3
	F40C-10	49.5	61.5	51	42	56.5	5.0	M6	17	16	M6	12	-	-	G1/8	8	11	-	6	14	-	60	2.0
50	F50A-*	40.5	48.0	62.5	50	70.5	6.8	M8	20	16	M8	13	-	-	G1/4	11.5	12.5	-	6	14	-	95	84
	F50B-*	40.5	48.0	62.5	50	70.5	6.8	M8	20	16	-	-	M12x1.25	24	G1/4	11.5	12.5	6	6	14	19	95	84
	F50C-5	45.5	53.0	62.5	50	70.5	6.8	M8	20	16	M8	13	-	-	G1/4	11.5	12.5	-	6	14	-	95	3.2
	F50C-10	50.5	58.0	62.5	50	70.5	6.8	M8	20	16	M8	13	-	-	G1/4	11.5	12.5	-	6	14	-	95	2.8
63	F63A-*	46	54	75.5	62	83.5	8.5	M10	22	20	M8	13	-	-	G1/4	11.5	12.5	-	6	17	-	150	135
	F63B-*	46	54	75.5	62	83.5	8.5	M10	22	20	-	-	M12x1.25	24	G1/4	11.5	12.5	6	6	17	19	150	135
	F63C-5	51	59	75.5	62	83.5	8.5	M10	22	20	M8	13	-	-	G1/4	11.5	12.5	-	6	17	-	150	6.7
	F63C-10	56	64	75.5	62	83.5	8.5	M10	22	20	M8	13	-	-	G1/4	11.5	12.5	-	6	17	-	150	6.0
80	F80A-*	53.5	63.5	96.5	82	103	8.5	M10	22	25	M10	15	-	-	G3/8	11.5	16	-	6	22	-	245	220
	F80B-*	53.5	63.5	96.5	82	103	8.5	M10	22	25	-	-	M16x1.5	32	G3/8	11.5	16	8	6	22	24	245	220
	F80C-5	58.5	68.5	96.5	82	103	8.5	M10	22	25	M10	15	-	-	G3/8	11.5	16	-	6	22	-	245	10.5
	F80C-10	63.5	73.5	96.5	82	103	8.5	M10	22	25	M10	15	-	-	G3/8	11.5	16	-	6	22	-	245	9.5
100	F100A-*	63	75	113	89	122	8.5	M10	22	25	M12	20	-	-	G3/8	15	21	-	6	22	-	385	360
	F100B-*	63	75	113	89	122	8.5	M10	22	25	-	-	M20x1.5	40	G3/8	15	21	10	6	22	30	385	360
	F100C-5	68	80	113	89	122	8.5	M10	22	25	M12	20	-	-	G3/8	15	21	-	6	22	-	385	11.0
	F100C-10	73	85	113	89	122	8.5	M10	22	25	M12	20	-	-	G3/8	15	21	-	6	22	-	385	10.0

* SPECIFY STROKE LENGTH WHILE ORDERING

Magnetic Sensors

For Cylinder Position Sensing

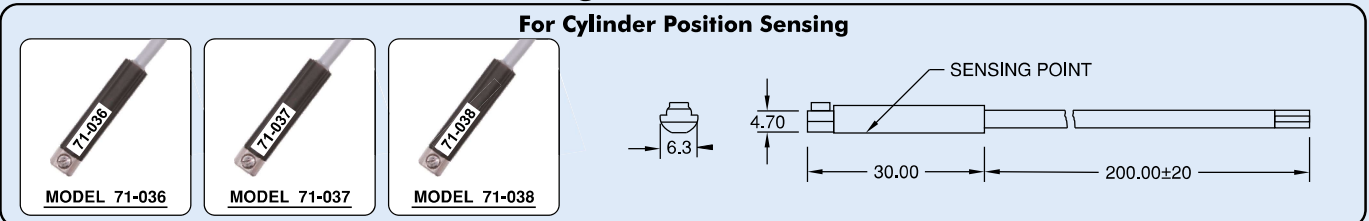

Compact Cylinders : Series 'D'

The Mounting Dimensions as per VDMA 24562

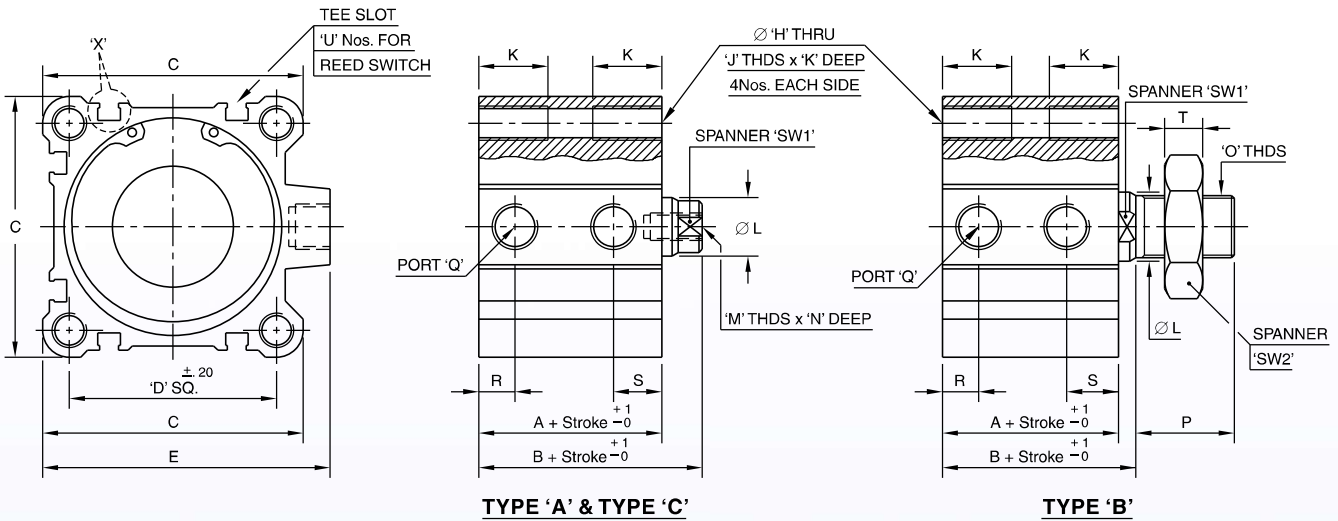

TYPE 'A' – DOUBLE ACTING, FEMALE THREADS, MAGNETIC PISTON
 TYPE 'B' – DOUBLE ACTING, MALE THREADS, MAGNETIC PISTON
 TYPE 'C' – SINGLE ACTING, FEMALE THREADS, SPRING RETURN, NON MAGNETIC PISTON

BORE DIA	MODEL No.	A	B	C	D SQ	E	Ø H	J THDS	K	Ø L	M THDS	N	O THDS	P	Q THDS	R	S	T	U	SW1	SW2	FORCE @ 5 bar (kgf)	
																						EXTEND	RETRACT
25	D25A-*	38.5	43.5	39	26	39	4.2	M5	17	10	M6	12	-	-	M5	8	10	-	3	8	-	22	18
	D25B-*	38.5	43.5	39	26	39	4.2	M5	17	10	-	-	M8x1.25	16	M5	8	10	5	3	8	17	22	18
	D25C-5	43.5	48.5	39	26	39	4.2	M5	17	10	M6	12	-	-	M5	8	10	-	3	8	-	22	2.0
	D25C-10	48.5	53.5	39	26	39	4.2	M5	17	10	M6	12	-	-	M5	8	10	-	3	8	-	22	1.4
32	D32A-*	35.5	42.5	45	32.5	49.5	5.0	M6	17	12	M8	16	-	-	G1/8	7.5	11	-	6	10	-	37	31
	D32B-*	35.5	42.5	45	32.5	49.5	5.0	M6	17	12	-	-	M10x1.25	22	G1/8	7.5	11	5	6	10	17	37	31
	D32C-5	40.5	47.5	45	32.5	49.5	5.0	M6	17	12	M8	16	-	-	G1/8	7.5	11	-	6	10	-	37	2.0
	D32C-10	45.5	52.5	45	32.5	49.5	5.0	M6	17	12	M8	16	-	-	G1/8	7.5	11	-	6	10	-	37	1.5
40	D40A-*	39.5	46.5	51	38	56.5	5.0	M6	17	16	M8	13	-	-	G1/8	8	11	-	6	14	-	60	48
	D40B-*	39.5	50.5	51	38	56.5	5.0	M6	17	16	-	-	M10x1.25	19	G1/8	8	11	6	6	14	19	60	48
	D40C-5	44.5	56.5	51	38	56.5	5.0	M6	17	16	M8	13	-	-	G1/8	8	11	-	6	14	-	60	2.3
	D40C-10	49.5	61.5	51	38	56.5	5.0	M6	17	16	M8	13	-	-	G1/8	8	11	-	6	14	-	60	2.0
50	D50A-*	40.5	48.0	62.5	46.5	70.5	6.8	M8	20	16	M10	15	-	-	G1/4	11.5	12.5	-	6	14	-	95	84
	D50B-*	40.5	48.0	62.5	46.5	70.5	6.8	M8	20	16	-	-	M12x1.25	22	G1/4	11.5	12.5	8	6	14	24	95	84
	D50C-5	45.5	53.0	62.5	46.5	70.5	6.8	M8	20	16	M10	15	-	-	G1/4	11.5	12.5	-	6	14	-	95	3.2
	D50C-10	50.5	58.0	62.5	46.5	70.5	6.8	M8	20	16	M10	15	-	-	G1/4	11.5	12.5	-	6	14	-	95	2.8
63	D63A-*	46	54	75.5	56.5	83.5	6.8	M8	20	20	M10	15	-	-	G1/4	11.5	12.5	-	6	17	-	150	135
	D63B-*	46	54	75.5	56.5	83.5	6.8	M8	20	20	-	-	M16x1.5	32	G1/4	11.5	12.5	8	6	17	24	150	135
	D63C-5	51	59	75.5	56.5	83.5	6.8	M8	20	20	M10	15	-	-	G1/4	11.5	12.5	-	6	17	-	150	6.7
	D63C-10	56	64	75.5	56.5	83.5	6.8	M8	20	20	M10	15	-	-	G1/4	11.5	12.5	-	6	17	-	150	6.0
80	D80A-*	53.5	63.5	96.5	72	103	8.5	M10	22	25	M12	20	-	-	G3/8	11.5	16	-	6	22	-	245	220
	D80B-*	53.5	63.5	96.5	72	103	8.5	M10	22	25	-	-	M16x1.5	28	G3/8	11.5	16	10	6	22	30	245	220
	D80C-5	58.5	68.5	96.5	72	103	8.5	M10	22	25	M12	20	-	-	G3/8	11.5	16	-	6	22	-	245	10.5
	D80C-10	63.5	73.5	96.5	72	103	8.5	M10	22	25	M12	20	-	-	G3/8	11.5	16	-	6	22	-	245	9.5
100	D100A-*	63	75	113	89	122	8.5	M10	22	25	M12	20	-	-	G3/8	15	21	-	6	22	-	385	360
	D100B-*	63	75	113	89	122	8.5	M10	22	25	-	-	M16x1.5	28	G3/8	15	21	10	6	22	30	385	360
	D100C-5	68	80	113	89	122	8.5	M10	22	25	M12	20	-	-	G3/8	15	21	-	6	22	-	385	11.0
	D100C-10	73	85	113	89	122	8.5	M10	22	25	M12	20	-	-	G3/8	15	21	-	6	22	-	385	10.0

* SPECIFY STROKE LENGTH WHILE ORDERING