

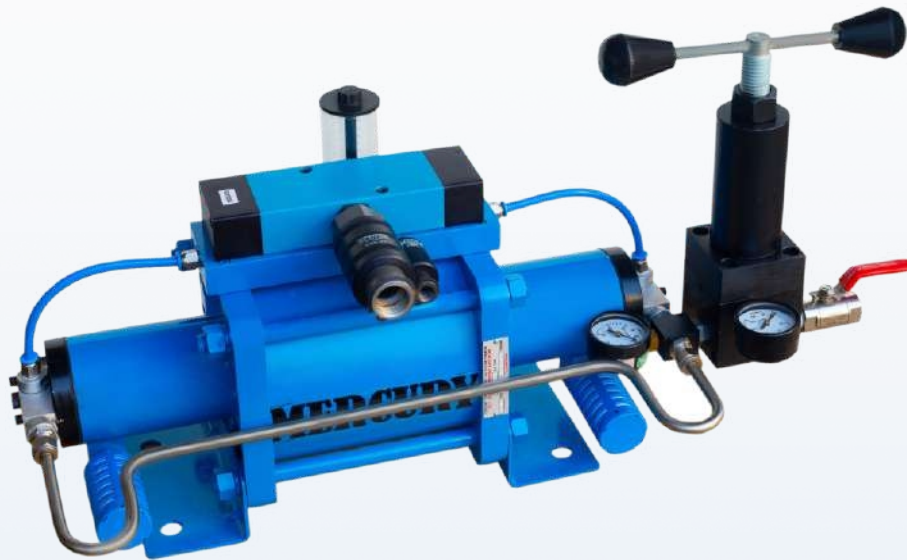

Series 'AB' Air Booster

The compact, Portable, Efficient and Economical solution to boost Shop compressed air pressure by 10 times



Salient Features

- Compact
- Energy Efficient
- Independent air inlet for main & Boosting chambers
- Special cooling chambers
- Automatic Lubrication

Mercury Pneumatics Pvt. Ltd.

C-105, Ansa Industrial Estate, Saki Vihar Rd, Andheri (E), Mumbai - 400072. India.
Ph.: +91-22-40151020

E-mail: contactus@mercuryindia.net Website: www.mercuryindia.net

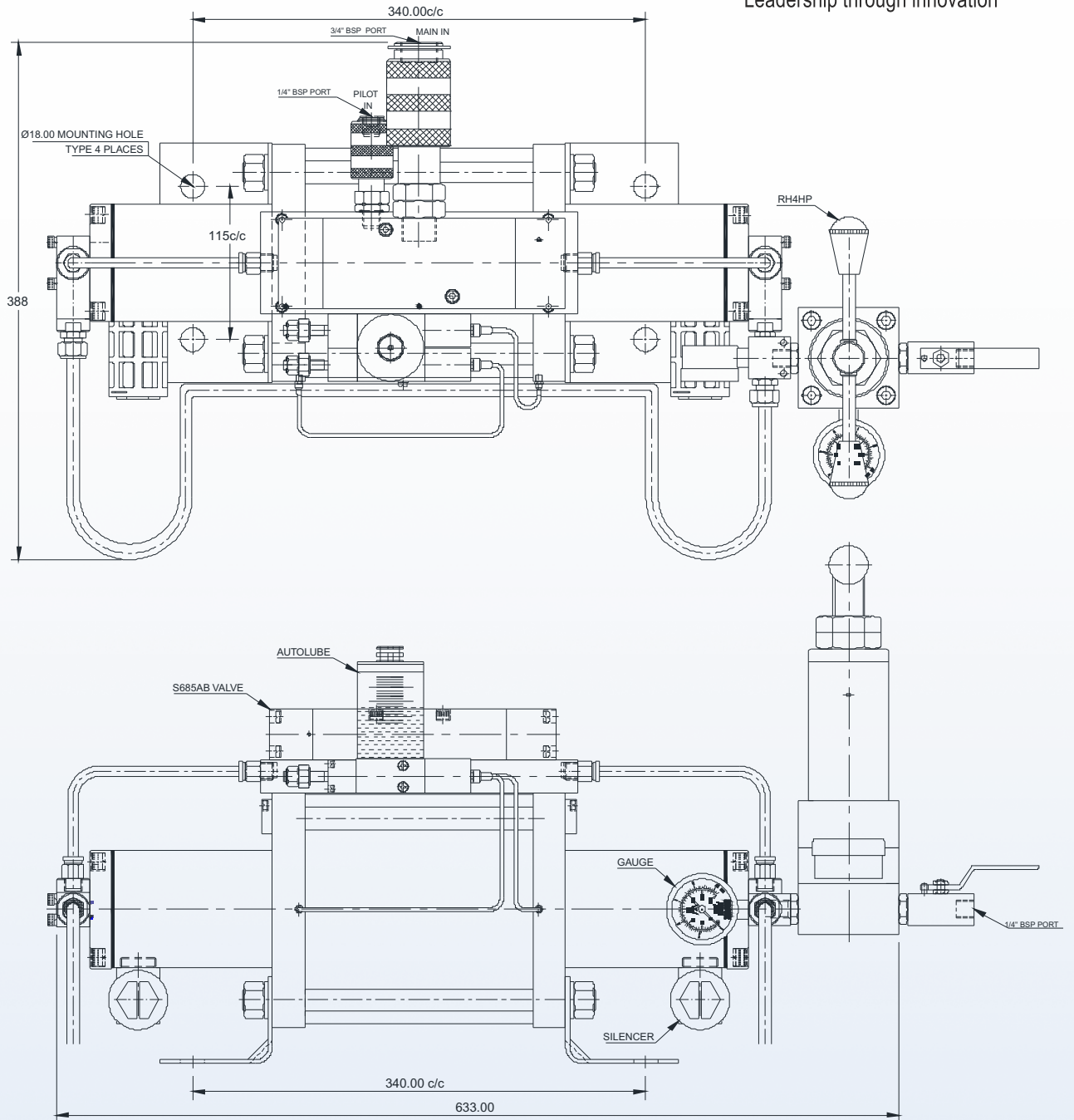

MODEL	RATIO
AB160-10	1 : 10
Minimum Working Pressure	2 BAR

RECIEVER TANK	DESCRIPTION
T1HP	1 LITRE TANK FOR AB160-10
T5HP	5 LITRE TANK FOR AB160-10

ITEMS INCLUDED IN STANDARD SUPPLY

- Inlet hand slide valves
- Outlet shut off valve
- High Pressure Regulator with guage
- Boosted Pressure gauge
- Autolube Pump

