

Typical Automatic Stretch Blow Moulding Machine for 'PET' Bottles



Hydro Pneumatic Mould Open-Close System



Neck Sealing Cylinder with Hollow Shaft



Stretch Pin Cylinder



Valve Regulator Assembly



Cushion (Deceleration) Solenoid Valves

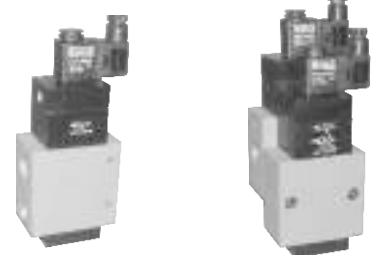

Single & Dual Blow Solenoid Valves

General Layout of Pneumatic System for Stretch Blow Moulding

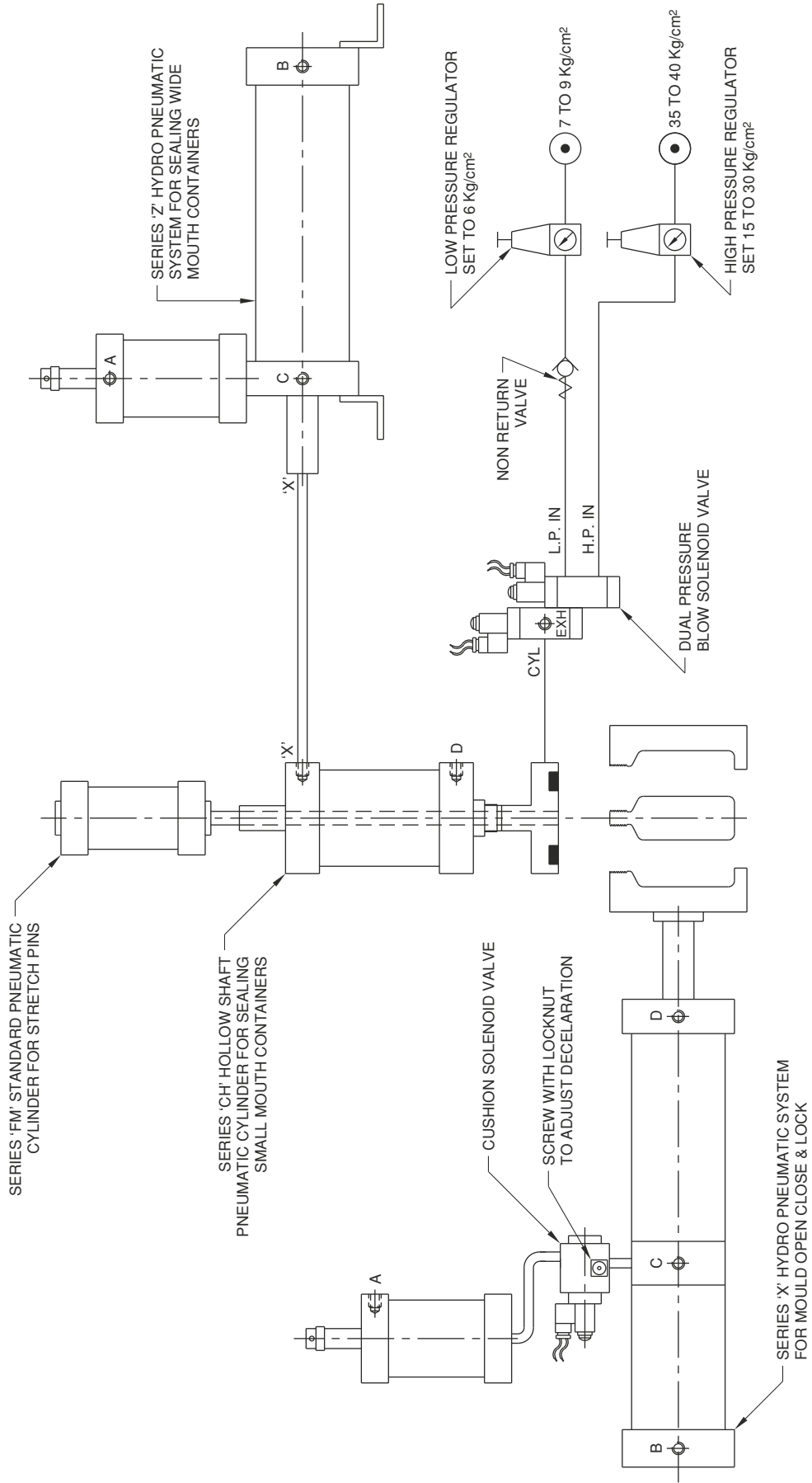

FIG. 1

1. General Description

- 1.1 The general layout of major pneumatic components used in stretch blow moulding machines is given in **Fig 1**.

“**MERCURY**” Series “**X**” and Series “**Z**” Hydro Pneumatic Clamping Systems use low cost pneumatic elements to achieve the large forces associated with pure hydraulic systems, with 50% saving in energy and 100% increase in speed over an equivalent hydraulic system.

The system has three stages of operation :-

- (a) Initial Low force, Large travel, Rapid Approach.
- (b) High Force, Short travel (typically 3mm), Power Stroke.
- (c) Low Force, Rapid Retraction.

The selection of the correct system is very important for efficient performance. General guidelines is given in the appropriate sections. Please feel free to contact us for further guidance if required.

1.2 Sequence of Operation

- (a) The heated perform is placed in the mould and the machine cycle is initiated by pressing 2 Hand Safety Push Buttons.
- (b) The Series “**X**” Clamp Cylinder closes the mould at High Speed with a low force (hence low compressed air consumption).
- (c) Just 3 to 5mm before the two halves of the mould touch, the **Cushion Solenoid Valve** is switched “**ON**”. This Cushions the closing of the mould and avoids banging and machine vibration. The rate of deceleration can be varied by adjusting screw on **Cushion Solenoid Valve**.
- (d) After the mould closes completely the **Power Stroke Solenoid Valve** of Series “**X**” Cylinder is switched “**ON**”. This causes the clamping pressure to increase by 20 times the regulated air pressure to **Power Stroke Solenoid Valve**. The mould is now held in the closed position by a very large force.
- (e) The **Neck Sealing Cylinder** now moves down and seals the neck and **Stretch Pin Cylinder** extends to stretch the preform to the desired length.
- (f) The low pressure solenoid of **Dual Pressure Blow Solenoid Valve** is switched “**ON**”, causing initial stretch and blow at low force. After a delay the high pressure solenoid of a **Dual Pressure Blow Solenoid Valve** is switch “**ON**” for final blow and forming.
- (g) After the set blow time, the air exhausts, and all cylinders retract rapidly.

NOTE :- The ideal cycle time is 5 to 7 seconds. This can be achieved by proper selection and location of valves and pipe fittings and tubing. Please feel free to contact us with your machine details to enable us to guide you correctly.

Piping Layout (Series 'X')

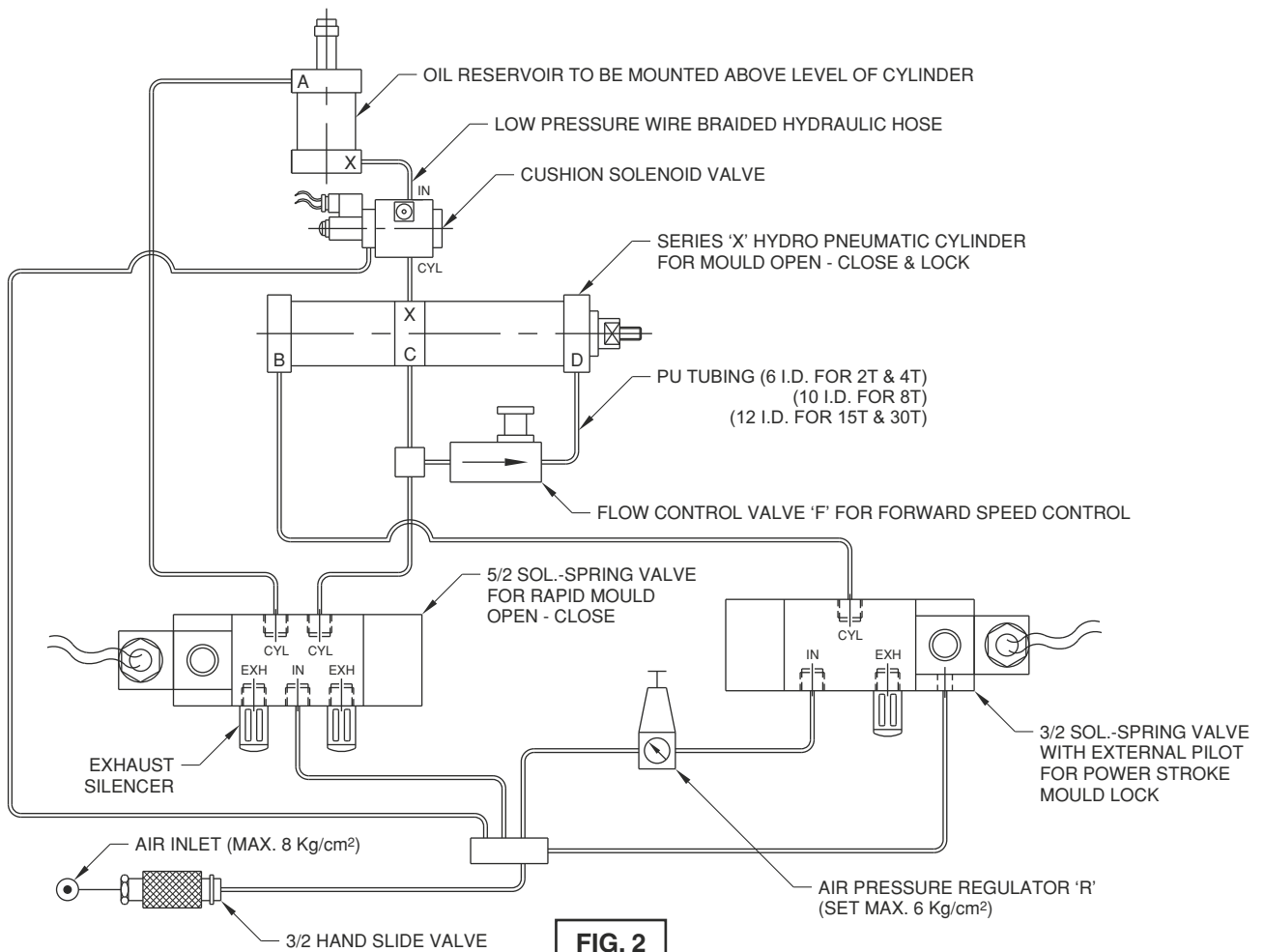

FIG. 2

Pneumatic Circuit Diagram (Series 'X')

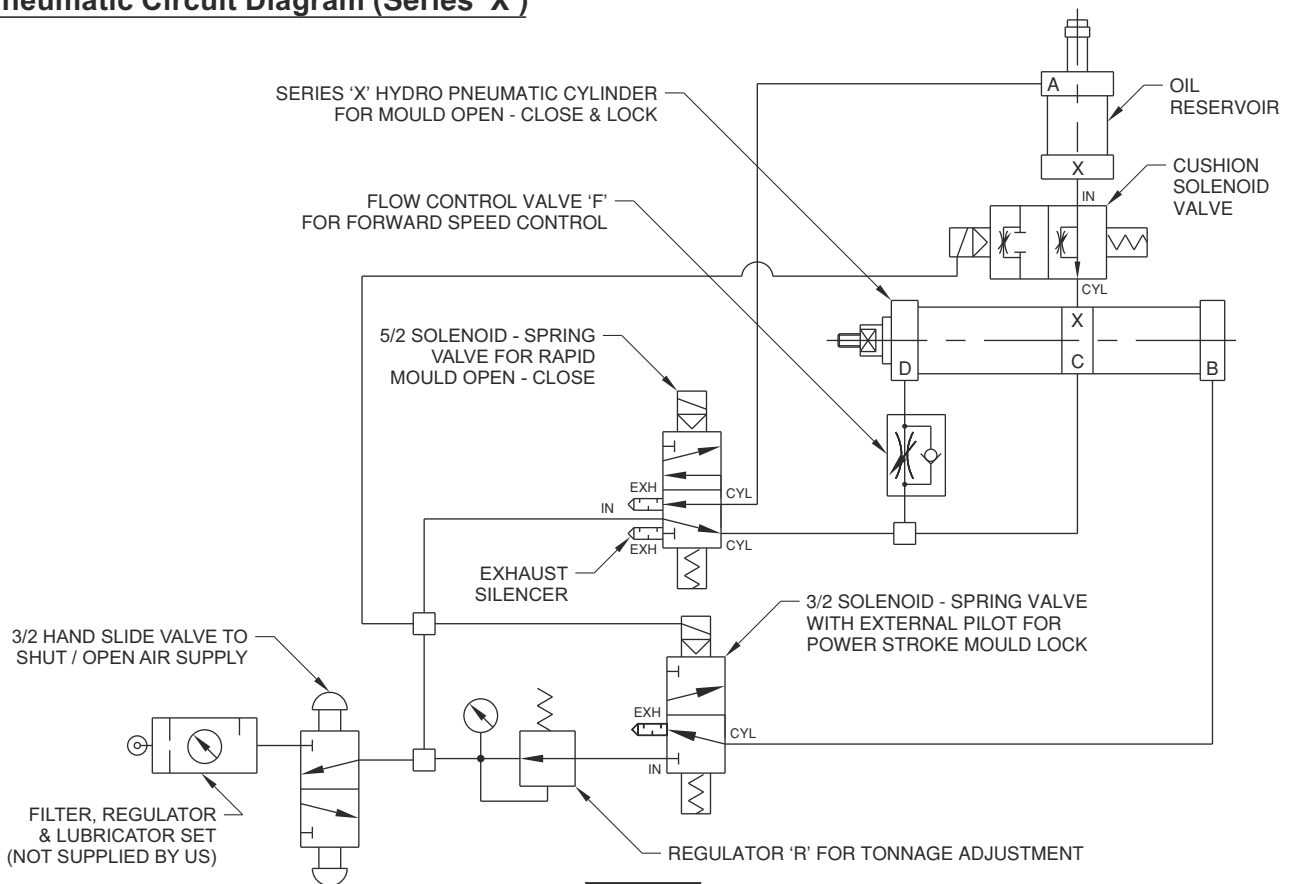

FIG. 3

2. Series “X” Hydro Pneumatic Press System

The **Series “X”** System has been developed for applications where the cylinder has to be mounted horizontally.

Refer to **Fig. 2** for Piping Layout, **Fig. 3** for Pneumatic Circuit and **Fig. 4** for overall dimensions and **Fig.6** for cut section details and spare parts list.

The system consists of a Hydraulic Cylinder and an Air to Oil Intensifier unit assembled as an integral unit. The Oil Reservoir is mounted vertically and coupled to the hydraulic cylinder through a suitable low pressure hydraulic hose. Alternatively, to achieve high speed and less heating of oil, the reservoir can be mounted vertically and Port “X” through a suitable connector.

An optional **Cushion Solenoid Valve** can be fitted in the oil line between the Reservoir and the Hydraulic Cylinder Port “X” to decelerate and close the moulds without jerks and vibration.

2.1 Sequence of Operation

- (a) When the **Approach Solenoid Valve** is switched “**ON**”, air is admitted to Port ‘A’ and exhausted from ‘C’ and port ‘D’. The Output Shaft extends rapidly, with a low force, due to air pressure acting on reservoir piston through port ‘A’.
- (b) When the two halves of the mould are about to close, the **Cushion Solenoid Valve** is switched “**ON**”. This cause the main oil flow from Reservoir to the Hydraulic Cylinder to shut and the oil is made to flow slowly through an adjustable Flow Control Valve incorporated in the **Cushion Solenoid Valve**. The Cylinder movement is thus decelerated and the mould closes slowly without a bang.
- (c) When the moulds close fully, the **Power Stroke Solenoid Valve** is switched “**ON**”. This causes regulated air to be admitted to port ‘B’. The Intensifier Piston now moves forward and oil pressure in the Hydraulic Cylinder is increased by 20 times the regulated air pressure. This high pressure oil now acts on the large diameter Hydraulic Cylinder to give the large clamping force. The clamping force can be varied by adjusting **Air Pressure Regulated ‘R’**.
- (d) After the machine cycle is over all the Solenoid Valves are switched “**OFF**”, causing air to be admitted to Port ‘C’ and Port ‘D’ and exhausted from port ‘A’ and port ‘B’. The Cylinder retracts rapidly.
- (e) To avoid vibration during mould opening, the **Cushion Solenoid Valve** can be switched “**ON**” just before the mould opens fully.

Series 'X' Hydro Pneumatic Press Cylinder : Basic Dimensions

Cylinder - Intensifier Unit

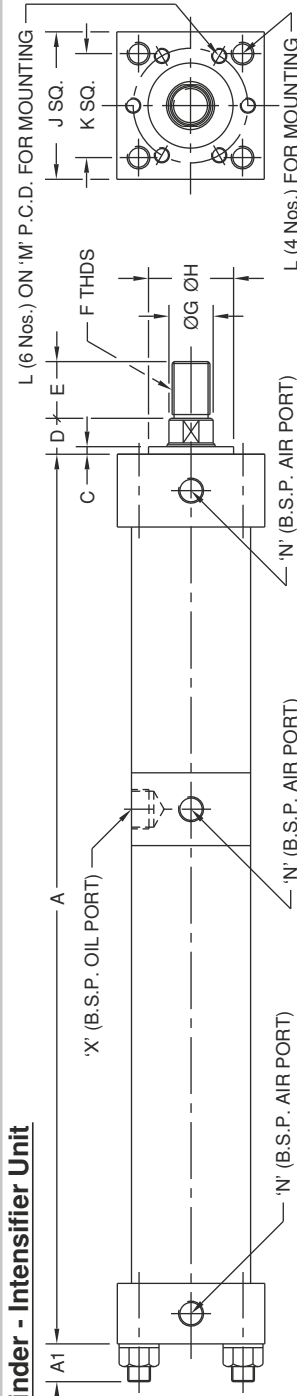

Reservoir

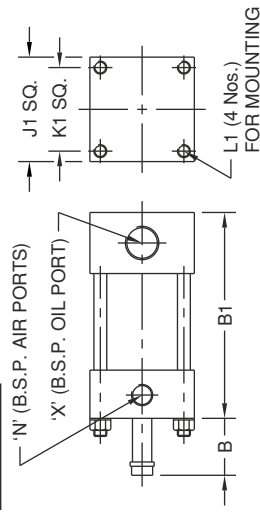

MODEL No.	TON	TOTAL STROKE	POWER STROKE	A	A1	B	B1	C	D	E	F	G	H	J	J1	K	K1	L	L1	M	N	X	FREE AIR CONSUMED / CYCLE IN LITS.	SEAL KIT
PO20X-100	2	100	3	381	15	150	210	4	19	30	M20x1.5	25.40	45	78	65	55	52	M12x1.75	M8x1.25	-	1/4"	1/2"	3.5	90-001
PO20X-150	2	150	3	431	15	200	260	4	19	30	M20x1.5	25.40	45	78	65	55	52	M12x1.75	M8x1.25	-	1/4"	1/2"	4.7	90-001
PO20X-200	2	200	3	481	15	250	310	4	19	30	M20x1.5	25.40	45	78	65	55	52	M12x1.75	M8x1.25	-	1/4"	1/2"	6.0	90-001
PO20X-250	2	250	3	531	15	300	360	4	19	30	M20x1.5	25.40	45	78	65	55	52	M12x1.75	M8x1.25	-	1/4"	1/2"	7.2	90-001
PO40X-100	4	100	3	413	21	156	227	4	22	35	M24x2	31.75	55	108	92	78	71.5	M16x2	M10x1.5	-	1/4"	3/4"	10.9	90-002
PO40X-150	4	150	3	463	21	206	277	4	22	35	M24x2	31.75	55	108	92	78	71.5	M16x2	M10x1.5	-	1/4"	3/4"	13.1	90-002
PO40X-200	4	200	3	513	21	256	327	4	22	35	M24x2	31.75	55	108	92	78	71.5	M16x2	M10x1.5	-	1/4"	3/4"	15.3	90-002
PO40X-250	4	250	3	563	21	306	377	4	22	35	M24x2	31.75	55	108	92	78	71.5	M16x2	M10x1.5	-	1/4"	3/4"	17.5	90-002
PO80X-100	8	100	3	449	30	144	222	4	24	35	M36x2	50.80	75	145	128	-	100	M16x2	M12x1.75	105	1/2"	3/4"	21.0	90-003
PO80X-150	8	150	3	499	30	194	272	4	24	35	M36x2	50.80	75	145	128	-	100	M16x2	M12x1.75	105	1/2"	3/4"	24.5	90-003
PO80X-200	8	200	3	549	30	244	322	4	24	35	M36x2	50.80	75	145	128	-	100	M16x2	M12x1.75	105	1/2"	3/4"	28.5	90-003
PO80X-250	8	250	3	599	30	294	373	4	24	35	M36x2	50.80	75	145	128	-	100	M16x2	M12x1.75	105	1/2"	3/4"	32.5	90-003
P150X-100	15	100	3	454.5	35	167	252	4	24.5	35	M40x2	62.30	90	182	168	-	130	M20x2.5	M16x2	125	1/2"	1"	41.3	90-005
P150X-150	15	150	3	504.5	35	217	302	4	24.5	35	M40x2	62.30	90	182	168	-	130	M20x2.5	M16x2	125	1/2"	1"	48.3	90-005
P150X-200	15	200	3	554.5	35	267	352	4	24.5	35	M40x2	62.30	90	182	168	-	130	M20x2.5	M16x2	125	1/2"	1"	57.7	90-005
P150X-250	15	250	3	604.5	35	317	402	4	24.5	35	M40x2	62.30	90	182	168	-	130	M20x2.5	M16x2	125	1/2"	1"	67.3	90-005
P300X-100	30	100	3	468	40	167	248	4	26	40	M48x3	62.30	90	205	175	-	140	M24x3	M16x2	150	1/2"	1"	47.0	90-018
P300X-150	30	150	3	518	40	217	298	4	26	40	M48x3	62.30	90	205	175	-	140	M24x3	M16x2	150	1/2"	1"	56.0	90-018
P300X-200	30	200	3	568	40	267	348	4	26	40	M48x3	62.30	90	205	175	-	140	M24x3	M16x2	150	1/2"	1"	66.0	90-018
P300X-250	30	250	3	618	40	317	398	4	26	40	M48x3	62.30	90	205	175	-	140	M24x3	M16x2	150	1/2"	1"	76.0	90-018

FIG. 4

To calculate the horse power of compressor required :-
 1HP = 120 LITRES OF FREE AIR (NL) PER MINUTE AT 5 Kg/Cm²
 N = NUMBER OF CYCLES PER MINUTE
 Q = FREE AIR CONSUMED PER CYCLE (FROM CHART) IN NORMAL LITRES (NL)
 POWER REQUIRED = $\frac{Q \times N}{120}$ (H.P.) OR $\frac{Q \times N}{120} \times 0.746$ (KW)

Flexible Coupling

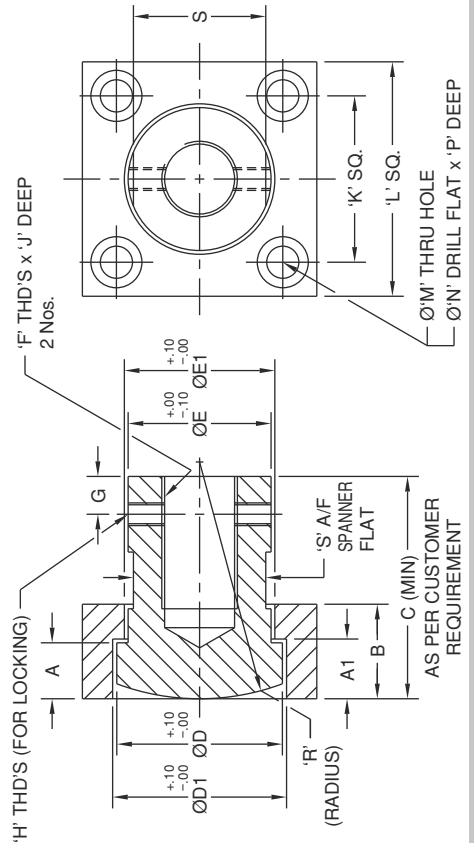

FIG. 5

TON	A	A1	B	C	D	D1	E	E1	F	G	H	J	K	L	M	N	P	R	S
2	14.8	15	25	58	43.8	44	37.8	38	M20x1.5	10	M6x1	35	44	62	8.5	13.5	12	125	35
4	14.8	15	30	71	57.8	58	44.8	45	M24x2	10	M6x1	40	52	75	8.5	13.5	15	275	42
8	14.8	15	30	78	63.8	64	49.8	50	M36x2	10	M6x1	40	58	78	10.5	16.5	15	375	46
15	14.8	15	30	98	77.8	78	64.8	65	M40x2	15	M8x1.25	40	72	98	12.5	19	15	600	60
30	19.8	20	40	134	87.8	88	74.8	75	M48x3	15	M8x1.25	45	80	105	12.5	19	15	775	70



Hollow Shaft Neck Sealing Cylinders (Series CH)

Piston dia 50, 80 and 125mm



Salient Features

- Extra long guided piston, with low friction 'U' seals.
- Precision honed barrel.
- Specially compounded rod wiper seal.
- Piston rod centreless ground and hard chrome plated.
- All mountings can be attached without dismantling the cylinder.

Operating Conditions

Media	: Air (filtered 40 μ & lubricated)
Temperature Range	: +5° to +50°C
Pressure Range	: Port 'A' 0.5 to 10 bar and Port 'B' 0.5 to 40 bar
Leakage	: Bubble Tight

Mechanical Characteristic

Barrel	: \varnothing 50 & 100 Aluminium alloy IS 63400 (6063T6)
	: \varnothing 125 Seamless Steel
Piston Rod	: Carbon steel IS 5517 - C35
End Caps	: Aluminium alloy IS 63400 (6063T6)
Seals	: Nitrile rubber, polyurethane (Viton for high temp. on request)



Basic Dimensions

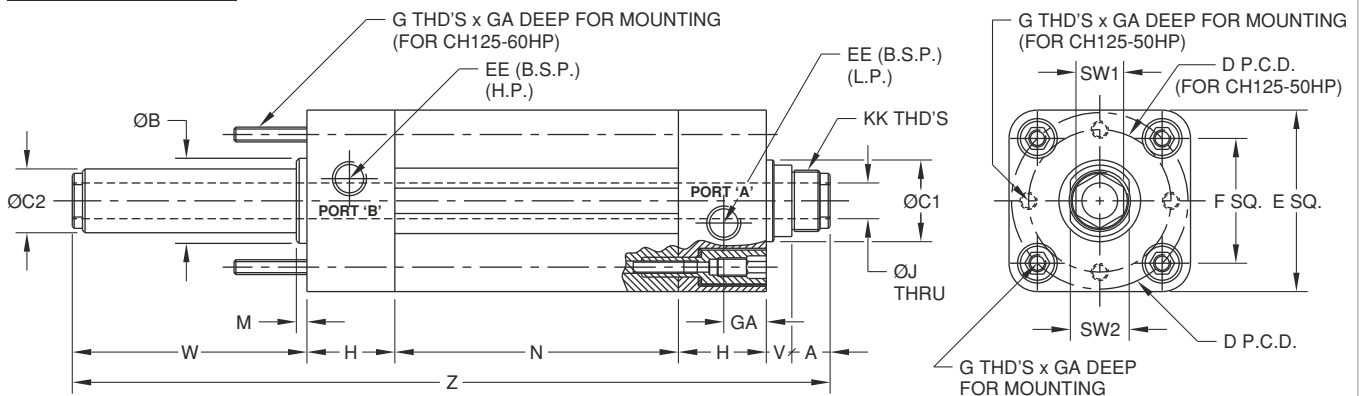

MODEL No.	PISTON \varnothing (mm)	A	\varnothing B	\varnothing C1	\varnothing C2	D (P.C.D.)	E (B.S.P.)	F	G	GA	H	J	KK	M	N	SW1	SW2	V	W	Z	SEAL KIT No.	
CH50-50HP(12)	50	15	40	25	20	68	69	1/4"	48	M6	17	30	12	M24x1.5	5	106	19	22	15	64	260	90-077
CH80-50HP(12)	80	15	48	32	25	100	98	1/4"	70.7	M8	15	30	12	M27x2.0	5	108	22	28	15	62	260	90-074
CH80-50HP(14)	80	15	48	32	25	100	98	1/4"	70.7	M8	15	30	14	M27x2.0	5	108	22	28	15	62	260	90-074
CH80-50HP(16)	80	15	48	32	25	100	98	1/4"	70.7	M8	15	30	16	M27x2.0	5	108	22	28	15	62	260	90-074
CH125-50HP(16)	125	11	48	32	25	90	144	1/4"	109	M10	16	30	16	M24x1.5	5	114	-	28	16	59	260	90-080
CH125-50HP(20)	125	11	48	32	25	90	144	1/4"	109	M10	16	30	20	M30x2.0	5	114	-	28	16	59	260	90-080
CH125-60HP(14)	125	20	78	50.8	35	154	144	1/2"	109	M16	68	36	14	M40x2.0	20	124	-	45	10	75	301	90-076

- The Series "CH" Double Acting, Hollow Through Rod Pneumatic Cylinders have been developed for sealing small neck diameter containers (upto 35 mm dia.). The piston rod has a through hole with replaceable bearing bushes to accommodate different sizes of stretch pins.
- Salient features of the Cylinder are :
 - Light weight, aluminium alloy barrel, end covers and piston. The barrel is precision honed.
 - Bronze filled teflon wear strip on the piston and Gun Metal bearing brushes in the end covers, to accommodate eccentric loads on the shaft.
 - Special profile 'U' Cup Seals for low friction and bubble tight sealing.
 - Mountings as per ISO 6431 Standards or as per customer specifications.
- In addition to the cylinders listed in this manual, we are in position to develop special cylinders as per customer specifications.
- Please specify Seal Kit No. While ordering spare seals.



Stretch Pin Cylinders (Series PL)

Piston dia 40 and 50mm

MERCURY

Salient Features

- Extra long guided piston, with low friction 'U' seals and unbreakable rubber magnet for reed switch actuation.
- International standard 'T' slots for reed switch.
- Precision honed barrel.
- Fine control cushion screw with lock at rear end, to prevent accidental removal.
- Specially compounded rod wiper seal.
- Piston rod centreless ground and hard chrome plated.
- All mountings can be attached without dismantling the cylinder.

Operating Conditions

Media	: Air (filtered 40 μ & lubricated)
Temperature Range	: +5° to +50°C
Pressure Range	: 0.5 to 10 bar
Leakage	: Bubble Tight

Mechanical Characteristic

Barrel	: Aluminium alloy IS 63400 (6063T6)
Piston Rod	: Carbon steel IS 5517 - C35
End Caps	: Aluminium alloy IS 63400 (6063T6)
Seals	: Nitrile rubber, polyurethane (Viton for high temp. on request)



Basic Dimensions

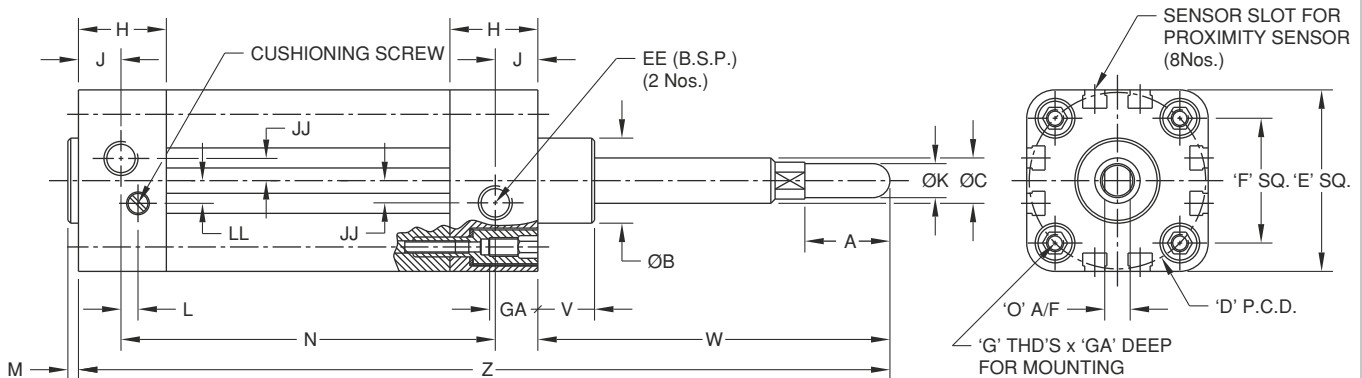

MODEL No.	PISTON Ø (mm)	A	ØB	ØC	D (P.C.D.)	E	EE (B.S.P.)	F	G	GA	H	J	JJ	K	L	LL	M	N	O	V	W	Z	SEAL KIT No.
PL40-400-12-330	40	10	35	12	56	57	1/4"	39.6	M6	16	29.5	13	4.5	11	11.5	9	4	479	10	5	330	835	90-054
PL50-400-12-330	50	10	40	12	68	69	1/4"	48.0	M8	17	30.0	15	7.0	11	6.5	13	4	476	10	5	330	836	90-053
PL50-600-16-375	50	10	40	16	68	69	1/4"	48.0	M8	17	30.0	15	7.0	15	6.5	13	4	676	14	5	375	1081	90-075
PL50-600-20-375	50	10	40	20	68	69	1/4"	48.0	M8	17	30.0	15	7.0	19	6.5	13	4	676	17	5	375	1081	90-085

5.1 The Series "PL" Double Acting Pneumatic Cylinders are manufactured as per IS 6431 Standards. In this Series, we manufacture the full range from 32 mm bore to 200 mm. The models included in this manual are supplied to the Stretch Blow Moulding Machine manufacturers for operation of the stretch pin.

5.2 Salient features of the Cylinders are :

- Light weight, aluminium alloy barrel, end covers and piston. The barrel is precision honed for low friction and long life of seals.
- Bronze filled teflon wear strip on the piston and Gun Metal bearing brushes in the end covers, to accommodate eccentric loads on the shaft.
- Special profile 'U' Cup Seals for low friction and bubble tight sealing.
- Built in permanent magnet in piston as standard. Reed Switches can be mounted on the barrel for sensing the motion of the cylinder.
- Long length cushioning with a fine thread adjustment screw for guaranteed declaration at high speeds.

5.3 Please specify Seal Kit No. While ordering spare seals.



3/4” & 1” BSP 2/2 (2 WAY) Normally Open Cushion Solenoid Valves



6.0 Cushion Solenoid Valves

- 6.1 These valves are fitted on our Series “X” Hydro Pneumatic Clamping Cylinders in the oil line between the Oil Reservoir and the Main Cylinder. The purpose of these valves is to avoid banging and vibration during mould opening and closing, when the machine is operated at high speed.
- 6.2 The valves consists of a 2 Way (2/2) Normally Open Solenoid Valve with a bypass Flow Control Valve. Just before the mould fully closes or fully opens, the Solenoid is switched “ON”. This shuts the rapid flow of oil from Reservoir to the Cylinder. The oil is now made to flow through a built in bypass Flow Control Valve to adjust the rate of deceleration, thus providing a smooth, cushioned mould closing and opening, which eliminates vibration and extends the life of the mould.
- 6.3 Refer to **Section 2** on page **2.06/13** for construction details and dimensions.

1/2" BSP 3/2 (3 WAY) High & Dual Pressure Blow Solenoid Valves



1/2" BSP 3/2 (3 WAY) High
Pressure Blow Solenoid Valve



1/2" BSP 3/2 (3 WAY) Dual
Pressure Blow Solenoid Valve

7.0 High & Dual Pressure Blow Solenoid Valves

7.1 The blowing pressure for PET is generally in the range of 15 to 25 Kg/cm². We have developed two types of 1/2" 3/2 Poppet type Solenoid Valves with external pilot for this application.

The **Single Solenoid Valve** feeds blow pressure when the coil is switched "**ON**" and exhausts air when the coil is switched "**OFF**".

The **Dual Pressure Double Solenoid Valve** first feeds low pressure (Max. 7 Kg/cm²) and when the preform is fully stretched, the high pressure solenoid is switched "**ON**" to provide final blow (Max. 30 Kg/cm²) for uniform forming. When both solenoids are switched "**OFF**" the blow air exhausts through the valve.

7.2 Refer to **Section 2** on page **2.06/11 & 2.06/12** for construction details and dimensions.

7.3 We do not recommend that these valves be serviced in the field. In case of failure, replace the valve and send it for repairs to our factory or nearest service centre. Always specify the model no. and nature of complaint while sending the valve for service.

8.0 Solenoid Valve - Regulator Assembly

1/4" & 1/2" BSP Valve-Regulator Assembly



STANDARD VRA2 & VRA4

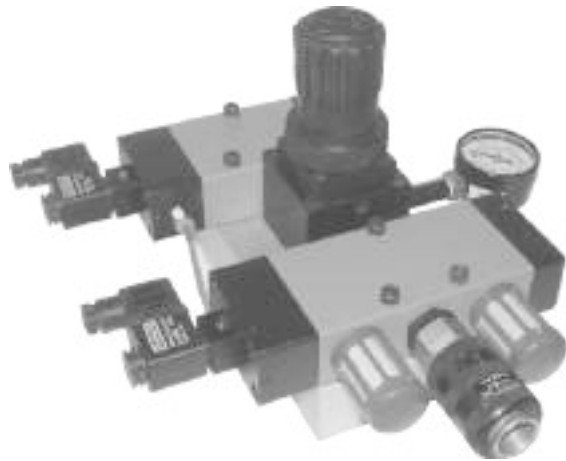

**SERIES 'X' & 'Z'
MODEL VRA2Z & VRA4Z**

- 8.1 For efficient operation of our Series 'X' and Series 'Z' Hydro Pneumatic Systems, we have developed a compact Valve - Regulator Assembly.

The Approach Solenoid Valve, Power Stroke Solenoid Valve and the Tonnage Regulator are Sub-base mounted on a special manifold block. In case of valve failure, they can be replaced quickly without opening any pipe fittings. This reduces down time considerably and eliminates the chances of wrong fitment of pipes and connectors during maintenance. There is also saving in piping cost and air consumption.

- 8.2 Refer to **Section 2** on page **2.06/4** & **2.06/5** for layout details and dimensions.
- 8.3 We do not recommend that our valves be serviced in the fields. In case of failure, replace the valves and send it for repairs to our factory or nearest service centre. Always specify the Model No. and nature of complaint while sending the valve for service.

9.0 High Pressure Regulator

1/2" BSP High Pressure Regulator



9.1 Our High Pressure Regulator Model RH4 is a piston type regulator that has been developed to overcome the failure of diaphragm type regulators under high pressure.

The salient features are :

- (i) Compact and light weight
- (ii) Well proportioned piston to spring ratio for fine control of output pressure.
- (iii) Few moving parts for easy servicing

9.2 Refer to **Section 2** on page **2.06/14** for technical specifications.

The regulator is a simple device and can be serviced in the field. Individual spare parts can be supplied. Please specify the Part No. while ordering.

10.0 Non Return Valve

1/2" BSP Non-return Valve



10.1 When our Dual Pressure Blow Solenoid Valve is used, our 1/2" Non Return Valve Model NR4 has to be fitted in the pipeline between the Low Pressure inlet of Dual pressure Blow Solenoid Valve and the Outlet of Low Pressure regulator. Refer to **Section 2** on page **2.05/2** for construction details and dimensions.