



Hydro Pneumatic Pumps
Series 'A'

MERCURY
Leadership through innovation

Hydro Pneumatic Pumps

The All New World Class

The efficient, economical alternative to centrifugal, vane, piston & plunger pumps and hand operated pumps

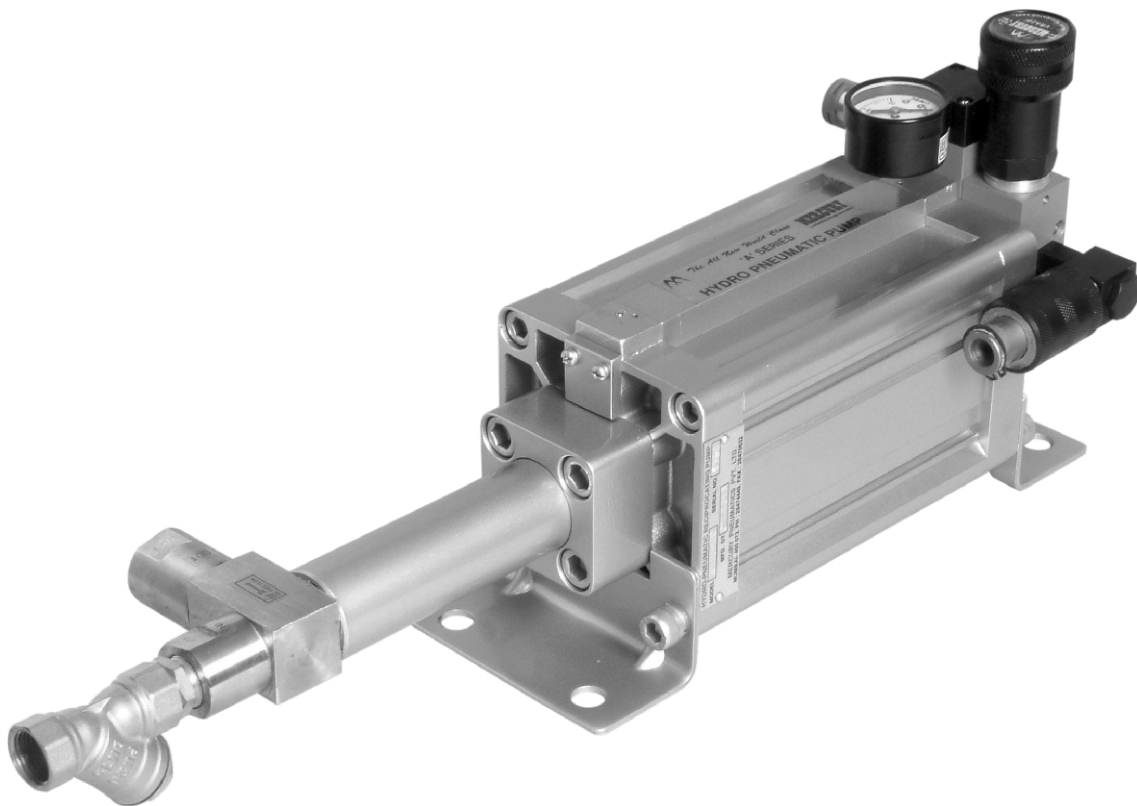

Typical Applications :

- Hydro static Pressure Testing
- Cyclic Pressure Testing
- Burst Strength Testing
- Operation of Hydraulic Jacks, Clamps & Presses
- Portable Systems for Construction, Mining & Defence Equipments
- Overload Protection of Mechanical Presses, Shears etc

1.0 General Description

1.1 The general layout of components used for proper installation of our Hydro Pneumatic Reciprocating Pump is shown in **Fig.1**. The principle of operation is given in **Fig. 2 and Fig. 3**.

NOTE : Items marked * are not supplied by us and have to be provided by the customer.

1.2 ADVANTAGES OF “MERCURY” HYDRO PNEUMATIC PUMPS

The New “**MERCURY**” Series “**A**” Hydro Pneumatic Reciprocating Pumps are an efficient, low cost alternative to motorised and hand operated pumps. The salient features are,

1. Compact and lightweight. Can be mounted in any orientation.
2. Low air consumption. When used in conjunction with a low pressure, high discharge centrifugal prefill pump, the energy consumption and time for building desired pressure is very low. Once pressure has built up there is no further consumption of compressed air.
3. Automatically compensates for leakages to maintain set pressure.
4. Can be used in explosive environments, as all components are pneumatically actuated.
5. Designed for use with water and other non corrosive liquids, as all wetted parts are made from stainless steel and brass.
6. Non return valve assembly can be easily dismantled for quick servicing.
7. Sub-base mounted valve regulator assembly for quick replacement and easy servicing.
8. 2/2 Plunger valves can be serviced without dismantling the pump.
9. Bleed hole to indicate high pressure water seal deterioration / failure.

General Layout of Pump Installation

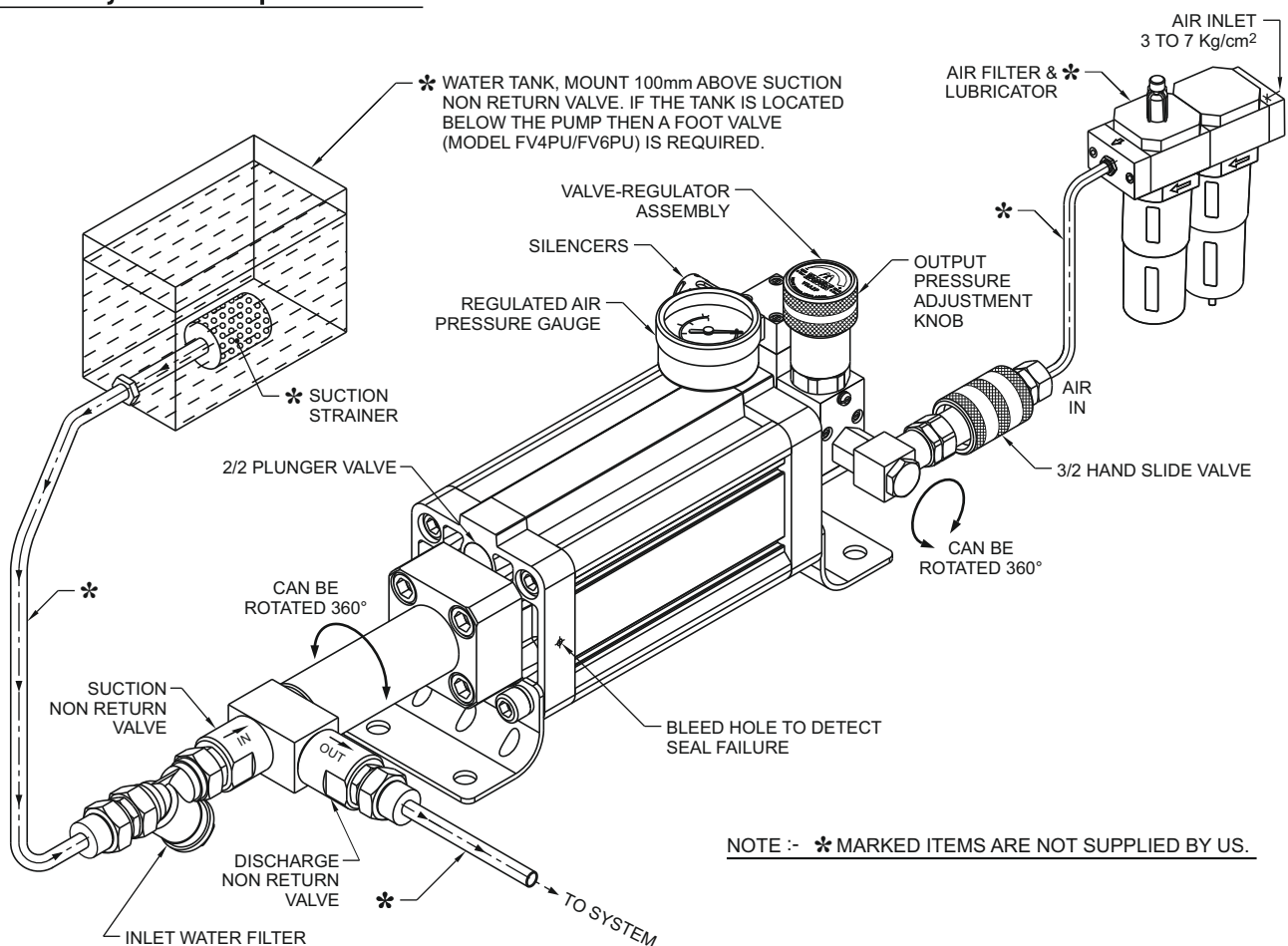

FIG. 1

DASH 1 INTENSIFIER

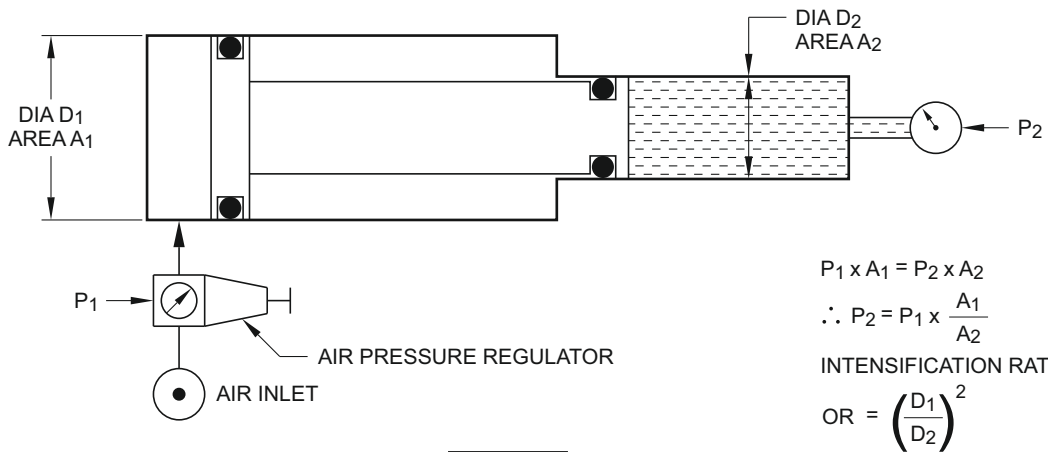

FIG. 2

PNEUMATIC CIRCUIT DIAGRAM FOR SERIES 'A' HYDRO PNEUMATIC RECIPROCATING PUMP

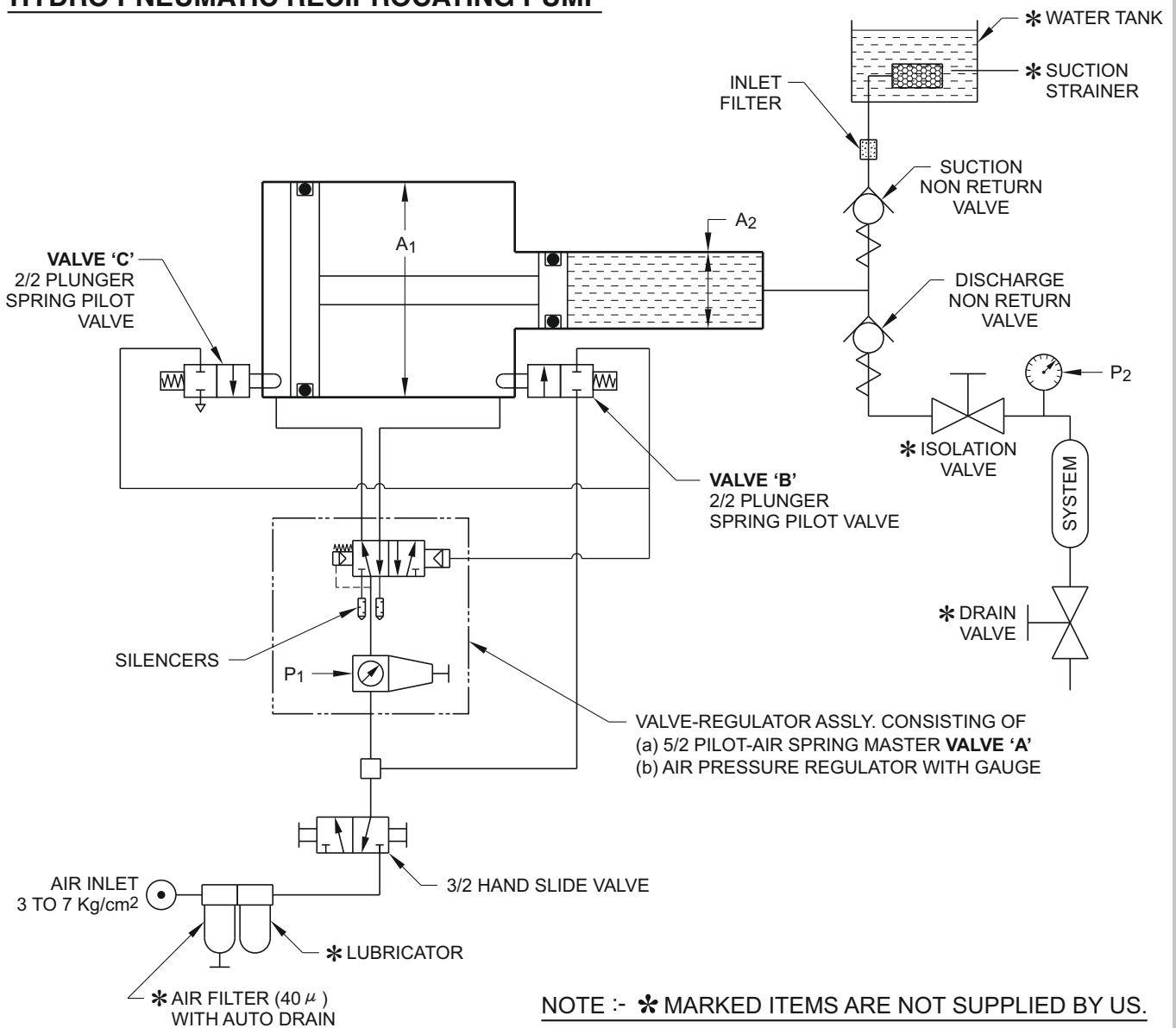

FIG. 3

1.3.0 Principles of Operation

1.3.1 The heart of “**MERCURY**” pumps is an air to liquid Intensifier or Booster which is diagrammatically shown in **Fig. 2**.

The pneumatic cylinder of large diameter **D1** is coupled to an hydraulic cylinder of small diameter **D2**. When regulated compressed air at pressure **P1** is applied on **D1**, the pressure of liquid in **D2** increases as per Pascals Law.

$$P_1 \times A_1 = P_2 \times A_2 \quad \text{Where } A_1 = \frac{\Pi}{4} \times D_1^2$$
$$\therefore P_2 = P_1 \times \frac{A_1}{A_2} \quad \text{and } A_2 = \frac{\Pi}{4} \times D_2^2$$

The ratio $\frac{A_1}{A_2}$ is called the intensification ratio.

The air to liquid intensifier shown in **Fig. 2** is converted into a pump by automatically reciprocating the pneumatic cylinder by suitable valves as shown in **Fig. 3**.

When regulated air at pressure **P1** is supplied through 5/2 pilot-spring **Valve A**, the cylinder piston starts moving to the right. When the piston presses the inbuilt 2/2 plunger **Valve B**, a pilot signal is given to the right end of **Valve A**, causing it to reverse and the cylinder piston starts moving to the left. When the piston presses inbuilt 2/2 plunger **Valve C**, the pilot air on right side of **Valve A** is exhausted, causing it to reverse and the piston starts moving to the right. Hence the pneumatic piston starts reciprocating continuously as long as compressed air is supplied.

On the liquid side of the pump, a suction and discharge non return valve assembly is fitted. When the piston moves to the left, vacuum is created in the hydraulic cylinder and liquid is sucked in due the opening of suction non return valve. When the piston moves to the right, the suction non return valve shuts and the sucked liquid is discharged through the discharge non return valve. The constant reciprocation of the cylinder causes suction and discharge of liquid in pulses. The discharged liquid is fed into the product which has to be pressurised.

As liquid fills into the product under test, the pressure starts rising and when it reaches value **P2**, the forces in the pump balance and the pump stops reciprocating automatically. If there is any leakage in the output line, the pump starts reciprocating automatically to compensate for the leakage and maintain output pressure **P2**.

Typical Pressure Testing Circuit

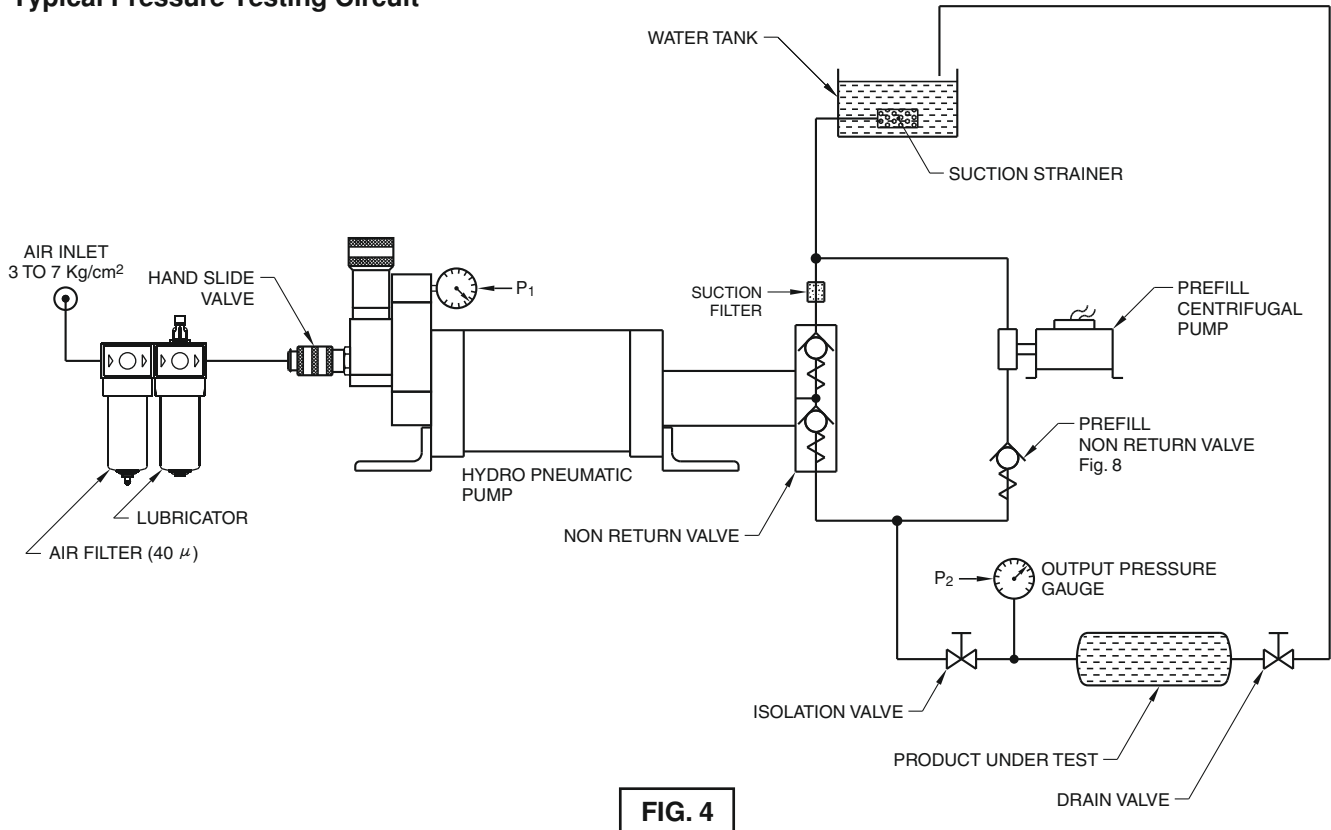

FIG. 4

1.4.0 Typical Applications

1.4.1 Hydrostatic Pressure Testing

One of the most popular applications of “**MERCURY**” Hydro Pneumatic Reciprocating Pumps is for pressure / burst testing of Castings, Valves, Hoses, Pressure Vessels etc.

The general layout of a hydrostatic pressure testing setup is shown in **Fig.4**.

The product under test (ex. casting) is first prefilled with water using a low pressure, high discharge “**CENTRIFUGAL PUMP**”. When all trapped air escapes and the casting is fully filled, the “**DRAIN**” valve and the “**CENTRIFUGAL PUMP**” are switched “**OFF**” and the “**HYDRO PNEUMATIC PUMP**” is switched “**ON**” by sliding “**Hand Slide Valve**” forward. When pressure in gauge **P2** rises to the value set in regulator **P1**, the “**ISOLATION**” valve is closed and after a slight delay the “**HYDRO PNEUMATIC PUMP**” should be switched “**OFF**” by sliding “**Hand Slide Valve**” backward. Any leakage in the product is detected by drop in pressure gauge **P2**.

After the test time, the drain valve is opened to release pressure and drain the water.

1.4.2 OTHER APPLICATIONS

Some of the other applications where “**MERCURY**” Hydro Pneumatic Pumps can be used as a low cost alternative to hand operated and motorised hydraulic pumps are:

- (i) Cyclic Pressure / life Testing of Pressure Gauges, Pressure Switches, Hoses etc.
- (ii) Burst Strength Testing of pressurised vessels such as LPG / Nitrogen / Oxygen gas cylinders, storage tanks, hoses, pipes etc.
- (iii) Seat leakage test of Control Valves.
- (iv) Operation of Single Acting Hydraulic Cylinders used in lifting platforms, hydraulic clamps, compression moulding presses etc.
- (v) Isostatic Pressing of powder metal and ceramics.
- (vi) Transferring of liquids from barrels, storage tank etc.
- (vii) Pumping oil or grease in centralized lubrication systems.



Technical Specification

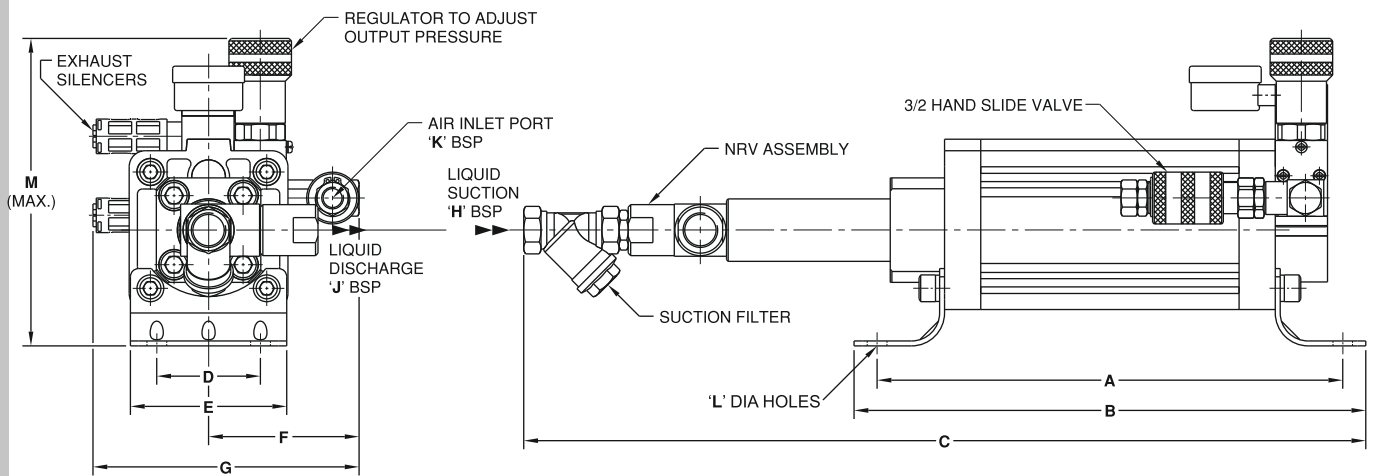

| MODEL No. | RATIO | OUTPUT PRESSURE AT 5Kg/cm ² | A | B | C | D | E | F | G | H BSP | J BSP | K BSP | Ø L | M | NRV MODEL |
|-----------|-------|--|-------|-------|-----|-----|-----|-------|-----|-------|----------|-------|-----|-----|-----------|
| A80-10 | 64 | 320 | 283 | 311 | 430 | 63 | 95 | 81.50 | 165 | 1/2" | 1/2" | 1/4" | 12 | 201 | HP2 |
| A80-14 | 32 | 160 | 283 | 311 | 530 | 63 | 95 | 81.50 | 165 | 1/2" | 1/2" | 1/4" | 12 | 201 | LP3 |
| A80-16 | 25 | 125 | 283 | 311 | 530 | 63 | 95 | 81.50 | 165 | 1/2" | 1/2" | 1/4" | 12 | 201 | LP3 |
| A80-20 | 16 | 80 | 283 | 311 | 530 | 63 | 95 | 81.50 | 165 | 1/2" | 1/2" | 1/4" | 12 | 201 | LP3 |
| A80-28 | 8 | 40 | 283 | 311 | 530 | 63 | 95 | 81.50 | 165 | 1/2" | 1/2" | 1/4" | 12 | 201 | LP3 |
| A80-32 | 6.25 | 31 | 283 | 311 | 530 | 63 | 95 | 81.50 | 165 | 1/2" | 1/2" | 1/4" | 12 | 201 | LP3 |
| A100-10 | 100 | 500 | 283 | 311 | 430 | 75 | 114 | 81.50 | 165 | 1/2" | 1/2" | 1/4" | 12 | 201 | HP2 |
| A100-14 | 51 | 255 | 283 | 311 | 530 | 75 | 114 | 81.50 | 165 | 1/2" | 1/2" | 1/4" | 12 | 201 | LP3 |
| A100-16 | 39 | 195 | 283 | 311 | 530 | 75 | 114 | 81.50 | 165 | 1/2" | 1/2" | 1/4" | 12 | 201 | LP3 |
| A100-20 | 25 | 125 | 283 | 311 | 530 | 75 | 114 | 81.50 | 165 | 1/2" | 1/2" | 1/4" | 12 | 201 | Lp3 |
| A100-28 | 12.75 | 64 | 283 | 311 | 530 | 75 | 114 | 81.50 | 165 | 1/2" | 1/2" | 1/4" | 12 | 201 | LP3 |
| A100-32 | 9.75 | 49 | 283 | 311 | 530 | 75 | 114 | 81.50 | 165 | 1/2" | 1/2" | 1/4" | 12 | 201 | LP3 |
| A100-40 | 6.25 | 31 | 301 | 329 | 548 | 75 | 114 | 81.50 | 165 | 3/4" | 3/4" | 1/4" | 12 | 201 | HF2 |
| A100-56 | 3 | 15 | 301 | 329 | 548 | 75 | 114 | 81.50 | 165 | 3/4" | 3/4" | 1/4" | 12 | 201 | HF2 |
| A160-14 | 130 | 650 | 336 | 386 | 482 | 115 | 180 | 169 | 216 | 3/4" | 1/2" | 1/2" | 18 | 259 | HP2 |
| A160-16 | 100 | 500 | 336 | 386 | 482 | 115 | 180 | 169 | 216 | 3/4" | 1/2" | 1/2" | 18 | 259 | HP2 |
| A160-20 | 64 | 320 | 336 | 386 | 482 | 115 | 180 | 169 | 216 | 3/4" | 1/2" | 1/2" | 18 | 259 | HP2 |
| A160-28 | 32 | 160 | 336 | 386 | 572 | 115 | 180 | 169 | 216 | 3/4" | 1/2" | 1/2" | 18 | 259 | LP3 |
| A160-32 | 25 | 125 | 336 | 386 | 572 | 115 | 180 | 169 | 216 | 3/4" | 1/2" | 1/2" | 18 | 259 | LP3 |
| A160-40 | 16 | 80 | 336 | 386 | 482 | 115 | 180 | 169 | 216 | 3/4" | 3/4" | 1/2" | 18 | 259 | HF2 |
| A160-56 | 8 | 40 | 336 | 386 | 482 | 115 | 180 | 169 | 216 | 3/4" | 3/4" | 1/2" | 18 | 259 | HF2 |
| A160-80 | 4 | 20 | 336 | 386 | 482 | 115 | 180 | 169 | 216 | 3/4" | 3/4" | 1/2" | 18 | 259 | HF2 |
| A160-20-2 | 128 | 640 | 511.5 | 561.5 | 660 | 115 | 185 | 76 | 280 | 1/2" | 1/2" | 1/2" | 18 | 365 | HP2 |
| A160-14-2 | 260 | 1300 | 511.5 | 561.5 | 660 | 115 | 185 | 76 | 280 | 1/2" | 1/2" | 1/2" | 18 | 365 | HP2 |
| A100-5 | 400 | 2000 | 273 | 305 | 411 | 75 | 114 | 81.50 | 165 | 1/2" | 9/16"UNF | 1/4" | 14 | 201 | HP3 |



5/2 PILOT-PILOT MASTER VALVES FOR PNEUMATICALLY OPERATED PUMP

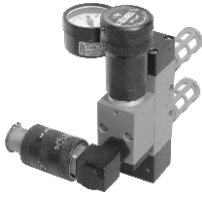

| PART No. | DESCRIPTION | SEAL KIT No. |
|----------|--------------------------|--------------|
| VRA2P | VALVE REGULATOR ASSEMBLY | SKVRA2P |
| VRA4P | | SKVRA4P |

SUCTION STRAINER



| PART No. | DESCRIPTION |
|----------|--|
| 40-6282 | SUCTION STRAINER FOR A-100-40,100-56,160-40, 160-56 & 160-80 |
| 40-8010 | SUCTION STRAINER FOR REST OF THE MODELS |

SILENCERS



| PART No. | DESCRIPTION |
|----------|--|
| SL2 | 1/4" SILENCER FOR 80 & 100 SERIES PUMP |
| SL4 | 1/2" SILENCER FOR 160 SERIES PUMP |

3/2 HAND SLIDE VALVES



| PART No. | DESCRIPTION | SEAL KIT No. |
|----------|--|--------------|
| SV2 | 1/4" HAND SLIDE VALVE FOR 80 & 100 SERIES PUMP | SKSV2 |
| SV4 | 1/2" HAND SLIDE VALVE FOR 160 SERIES PUMP | SKSV4 |

HIGH PRESSURE SUCTION & DISCHARGE NON-RETURN VALVE



| PART No. | DESCRIPTION | SEAL KIT No. |
|----------|---|--------------|
| HP2 | HIGH PRESSURE NON-RETURN VALVE | SKHP2 |
| HP3 | HIGH PRESSURE NON-RETURN VALVE FOR MODEL No. A100-5 | SKHP3 |

HIGH FLOW SUCTION & DISCHARGE NON-RETURN VALVE

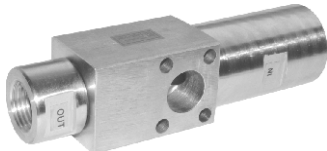

| PART No. | DESCRIPTION | SEAL KIT No. |
|----------|----------------------------|--------------|
| HF2 | HIGH FLOW NON-RETURN VALVE | SKHF2 |

STANDARD SUCTION & DISCHARGE NON-RETURN VALVE



| PART No. | DESCRIPTION | SEAL KIT No. |
|----------|-------------------------------|--------------|
| LP3 | LOW PRESSURE NON-RETURN VALVE | SKLP3 |

NON RETURN VALVE WITH 1/2" PORTS



| PART No. | DESCRIPTION | SEAL KIT No. |
|----------|-----------------------|--------------|
| NR4PUD | 1/2" NON-RETURN VALVE | 59-079 |

SUCTION FOOT VALVE

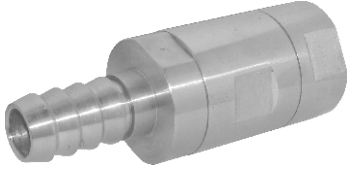

| PART No. | DESCRIPTION | SEAL KIT No. |
|----------|---------------|--------------|
| FV6PU | 1" FOOT VALVE | 59-080 |

SUCTION FOOT VALVE



| PART No. | DESCRIPTION | SEAL KIT No. |
|----------|-----------------|--------------|
| FV4PU | 1/2" FOOT VALVE | 59-081 |

AIR PRESSURE GAUGE



| PART No. | DESCRIPTION |
|----------|--|
| 20-938 | 1/8", Ø40 DIAL, 0 to 10 bar AIR PRESSURE GAUGE |